



# Regional Workshop on the Use of PCT Products

## Session 2

### Accessing to the PCT Products and Other Offices' Work

**Tokyo, Japan**  
**September 13-14, 2016**

Mr. Kenichiro NATSUME  
Director  
PCT International Cooperation Division  
Patents and Technology Sector

# Contents

- Introduction to
  - Patentscope
  - WIPO-CASE
  - Espacenet
  
- Demonstration of Patentscope
  
- (in the afternoon) Exercises to use Patentscope

# Patentscope



## PATENTSCOPE

Search International and National Patent Collections

[Mobile](#) | [Deutsch](#) | [Español](#) | [Français](#) | [日本語](#) | [한국어](#) | [Português](#) | [Русский](#) | [中文](#) | [العربية](#)

WORLD INTELLECTUAL PROPERTY ORGANIZATION

[Search](#)

[Browse](#)

[Translate](#)

[Options](#)

[News](#)

[Login](#)

[Help](#)

[Home](#) > [IP Services](#) > [PATENTSCOPE](#)

### Simple Search

Using PATENTSCOPE you can search 58 million patent documents including 3 million published international patent applications (PCT). Detailed coverage information can be found here [\(->\)](#)

Front Page



Office: All

[Search](#)

PCT Publication 35/2016 (2016/09/01) is now available. The next publication date is scheduled as follows: Gazette number 36/2016 (2016/09/09). [More](#)

**WIPO | PCT**  
The International  
Patent System

## Search Page

Front Page  Office: All

## Result List

Sort by: Pub Date Desc View Simple List Length 10 Machine translation							
No	Ctr	Title	PubDate	Int.Class	Appl.No	Applicant	Inventor
1.	WO	<a href="#">WO/2013/044242</a> - ELECTRIC BICYCLE	28.03.2013	B62M 6/40	PCT/US2012/056935	FARADAY BICYCLES, INC.	VOLLMER, Adam, Patrick
2.	WO	<a href="#">WO/2013/041276</a> - METHOD FOR AUTOMATICALLY DRIVING THE ELECTRIC MOTOR OF A BICYCLE AND CORRESPONDING CONTROL DEVICE	28.03.2013		PCT/EP2012/064870	ROBERT BOSCH GMBH	WALDE, Norbert
3.	WO	<a href="#">WO/2013/042319</a> - HUMAN-POWERED DRIVE FORCE DETECTION APPARATUS FOR ELECTRIC BICYCLE	28.03.2013	B62M 6/50	PCT/JP2012/005417	PANASONIC CORPORATION	TAKAMI, Hiroyuki
4.	EP	<a href="#">2566750</a> - METHOD AND DEVICE FOR AUTOMATICALLY CONTROLLING THE SPEED OF AN ELECTRIC BICYCLE TRANSMISSION	13.03.2013	B62M 25/08	11714051	BOSCH GMBH ROBERT	DURDEVIC IVICA

## Detail Page

**1. (WO2013044242) ELECTRIC BICYCLE**

PCT Biblio. Data Description Claims National Phase Notices Documents

**Pub. No.:** WO/2013/044242 **International Application No.:** PCT/US2012/056935  
**Publication Date:** 28.03.2013 **International Filing Date:** 24.09.2012

**IPC:** B62M 6/40 (2010.01), B62K 3/02 (2006.01), B62M 6/45 (2010.01)

**Applicants:** FARADAY BICYCLES, INC. [US/US]; 100 Forest Avenue Palo Alto, CA 94301 (US) (For All Designated States Except US).

**Title**  
**(EN)** ELECTRIC BICYCLE  
**(FR)** BICYCLETTE ÉLECTRIQUE

**Abstract:**  
**(EN)**An electric bicycle and electric bicycle frame including batteries stored in a pair of substantially parallel top tubes. In some cases, the top tubes extend rearward of the bicycle seat tube, and an electronics housing may be disposed between the rearward extending top tube portions.  
**(FR)**La présente invention porte sur une bicyclette électrique et un cadre de bicyclette électrique comprenant des batteries stockées dans une paire de



# Search Forms – Examples

## (Simple Search, Advanced Search, Field Combination)

Simple Search

Front Page  PCT, Office: Unite

Advanced Search

Search For:  ?

Language:  Stem:  Office: PCT, United States of America [Specify](#) ⇌

Field Combination

	Front Page	=	<input type="text" value="electric NEAR bicycle"/>	?
AND	WIPO Publication Number	=	<input type="text"/>	?
AND	Applicant Name	=	<input type="text"/>	?
AND	Office Code	=	<input type="text"/>	?
AND	English Description	=	<input type="text"/>	?
AND	English Claims	=	<input type="text"/>	?
AND	Licensing availability	=	<input type="checkbox"/>	
AND	Inventor Name	Is Empty:	<input checked="" type="radio"/> N/A <input type="radio"/> Yes <input type="radio"/> No	

Language  Stem:  Office: PCT, United States of America [Specify](#) ⇌

**109 results**

Search International and National Patent Collections

WORLD INTELLECTUAL PROPERTY ORGANIZATION

[Search](#) | [Browse](#) | [Translate](#) | [Options](#) | [News](#) | User: [ken.natsume@wipo.int](#) | [Help](#)
[Home](#) > [IP Services](#) > [PATENTSCOPE](#)

Results 1-10 of 1,694 for Criteria:FP:(electric NEAR bicycle) Office(s):all Language:EN Stemming: true

 prev 1 2 3 4 5 6 7 8 9 10 next Page: 1 / 170 [Go >](#)

 Refine Search 

**Analysis**

 Sort by: [Pub Date Desc](#) View: [All](#) List Length: 10

No	Ctr	Title	PubDate	Int.Cl.	Inventor	Applicant	Inventor
1.	WO	<a href="#">WO/2013/132535 - ELECTRIC BICYCLE</a>	12.09.2013	B62M 6/00	2/001578	PANASONIC CORPORATION	KAWAKAMI, Masafumi
<p>Provided is an <b>electric bicycle</b> configured so that, while production cost is prevented from increasing and an increase in the size of a hanger is kept to a minimum, the diameter of the joining sections of a crankshaft where the crankshaft is joined to crank arms can be increased, and the torque sensor can be installed within a hanger. A crankshaft (17) is configured so as to be divided into a crankshaft body (17A) which has a torque sensor (23) disposed on the outer peripheral side thereof and into an auxiliary crankshaft (17B) which is connected to one side of the crankshaft body (17A). Also, the diameter (D1) of the joining section of the auxiliary crankshaft (17B) where the auxiliary crankshaft (17B) is joined to a crank arm (18B) and the diameter (D3) of the joining section of the crankshaft body (17A) where the crankshaft body (17A) is joined to a crank arm (18A) are formed to be greater than the diameter (D2) of the connecting section of the crankshaft body (17A) where the crankshaft body (17A) is connected to the auxiliary crankshaft (17B).</p>							
2.	US	<a href="#">20130231810 - INTEGRATED ANTI-THEFT DEVICE FOR AN ELECTRIC BICYCLE</a>	05.09.2013	B62M 6/00	13777116	GM GLOBAL TECHNOLOGY OPERATIONS LLC	GARCIA Pierre-Olivier
<p>A drive unit for an <b>electric bicycle</b> comprising an <b>electric motor</b> and an energy storage device is provided. The drive unit includes a locking mechanism for locking the energy storage device and a control device. The control device is operatively connected to an actuator of the locking mechanism for the energy storage device. The actuator is fastened detachably to the drive unit. The control device is configured to evaluate signals received via a terminal in order to release or block one function of the drive unit as a function of at least one received signal. An <b>electric bicycle</b>, a method for operating an <b>electric bicycle</b> and a computer readable medium also are provided.</p>							
3.	US	<a href="#">20130228406 - Brake operating device of electric bicycle with sensor</a>	05.09.2013	B62L 3/02	13410261	TSAI SZU-FANG	TSAI SZU-FANG
<p>A brake operating device of an <b>electric bicycle</b> is provided with a brake lever including a projecting plate at one end, and a bifurcated cable anchoring member pivotably secured to the projecting plate; a magnetic member adhered to one side of the cable anchoring member; a housing pivotably secured to the brake lever and including a hydraulic cylinder and a cylindrical socket including an opening distal the brake lever, and internal threads proximate the opening; a spring depressible sensor including a sensing member disposed in the socket, and an electric wire extending from the sensing member; a hollow threaded fastener adjustably threadably secured to the internal threads of the socket to engage the sensing member; and a cylindrical member releasably mounted proximate to the opening and secured to the fastener. The electric wire passes the fastener and leaves the housing.</p>							
4.	US	<a href="#">20130228405 - BRAKE OPERATING DEVICE OF ELECTRIC BICYCLE WITH HALL-EFFECT SENSOR</a>	05.09.2013	B62L 3/02	13410244	Tsai Szu-Fang	Tsai Szu-Fang

Results 1-10 of 109 for Criteria:FP:(electric NEAR bicycle) Office(s):wo Language:EN Stemming: true



prev 1 2 3 4 5 6 7 8 9 10 next Page:1 / 11 Go >

Refine Search FP:(electric NEAR bicycle)

Search



Sort by: Pub Date Desc View Image List Length 10

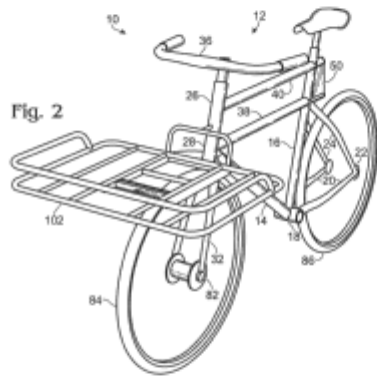

Fig. 1

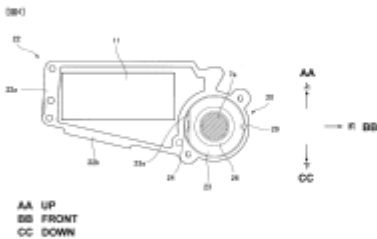
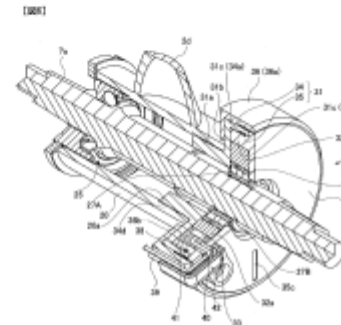

FIG 2

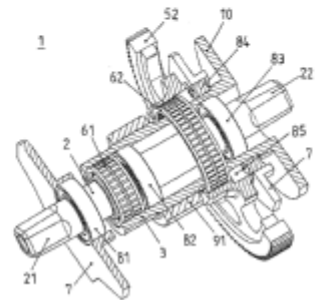
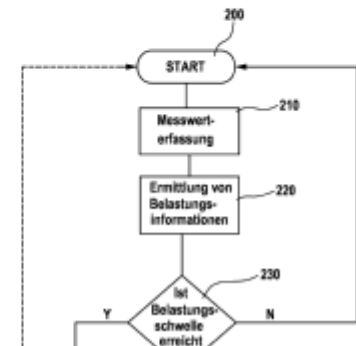

Fig. 2



## 39. (WO2000040456) AUTOMATIC TRANSMISSION FOR ELECTRIC BICYCLE

PCT Biblio. Data

Description

Claims

National Phase

Notices

Documents

Latest bibliographic data on file with the International Bureau

PermaLink

Pub. No.: WO/2000/040456 International Application No.: PCT/KR1999/000678  
 Publication Date: 13.07.2000 International Filing Date: 11.11.1999  
 Chapter 2 Demand Filed: 04.08.2000

IPC: *B60K 17/04* (2006.01), *B62M 13/02* (2006.01), *B62M 6/60* (2010.01), *B62M 6/65* (2010.01),  
*B62M 6/70* (2010.01), *B62M 6/75* (2010.01), *F16D 11/10* (2006.01), *F16H 3/083* (2006.01),  
*F16H 3/089* (2006.01), *F16H 61/02* (2006.01)

Applicants: HONG, Seok-Gi [KR/KR]; (KR)

Inventors: HONG, Seok-Gi; (KR)

Agent: PARK, Tae-Woo; 3rd Fl., 1576-1, Woosan-dong Kwangsan-gu Kwangju-City 506-050 (KR)

Priority Data: 1999/00590 07.01.1999 KR  
 1999/46135 22.10.1999 KR

Title (EN) AUTOMATIC TRANSMISSION FOR ELECTRIC BICYCLE  
 (FR) TRANSMISSION AUTOMATIQUE POUR BICYCLETTE ELECTRIQUE

Abstract: (EN) There are provided an automatic transmission for an electric bicycle comprising a mechanical gear shifting means and an electronic gear shifting means for mechanically and electronically shifting an output of the motor according to a magnitude of friction force between the wheel and ground and transferring the shifted output of the motor to the driving member; a moving housing in which the motor, the driving member, the power transmitting means, the mechanical and electric gear shifting means are mounted; a fixed housing which is fixedly disposed at an outer side of the moving housing; and a first rotational shaft which penetrates through the driving member, the moving housing, and is rotatably fixed to the fixed housing, wherein, while the moving housing is revolved with the rotational shaft in the center according to the magnitude of load exerted on the wheel of the bicycle, the output of the motor is changed through the mechanical and electronic gear shifting means and then transferred to the driving member.

(FR) L'invention porte sur une transmission automatique de bicyclette électrique, cette transmission comprenant

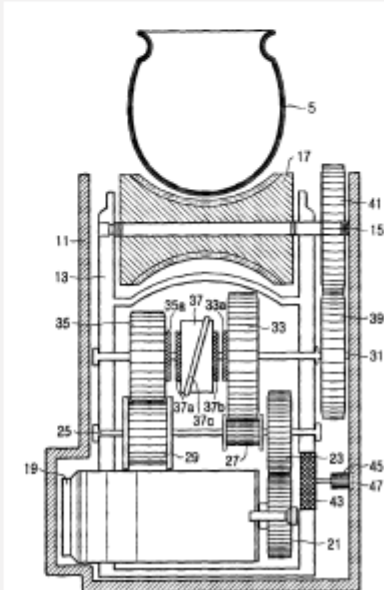



# Machine Translation of Description/Claims

[Search](#)
[Browse](#)
[Translate](#)
[Options](#)
[News](#)
[Login](#)
[Help](#)
[Home](#) > [IP Services](#) > [PATENTSCOPE](#)

## 17. (WO2014047629) विद्युत साइकिल

पीसीटी	Biblio. तिथि	विवरण	दावा	राष्ट्रीय चरण	नोटिस	चित्र	दस्तावेज़
--------	--------------	-------	------	---------------	-------	-------	-----------

नोट: स्वतः ऑप्टिकल कैरेक्टर मान्यता प्रक्रियाओं पर आधारित पाठ. कानूनी मामलों के लिए पीडीएफ संस्करण का उपयोग करें

विद्युत साइकिल

संबंधित आवेदन को पार संदर्भ

अमेरिका पेटेंट आवेदन सीरियल नं. इस आवेदन का दावा प्राथमिकता एतद्वारा संदर्भ द्वारा शामिल कर रहे हैं जो 1 अप्रैल 2013, दायर की 24 सितंबर, 2012 दायर / 625666 13, और / 854771 13.

पृष्ठभूमि

परम्परागत बिजली साइकिल आमतौर पर साइकिल फ्रेम के बाहर करने के लिए विभिन्न तरीकों से जुड़े होते हैं कि एक या एक से अधिक housings में शामिल एक बैटरी पैक और इलेक्ट्रॉनिक्स पर भरोसा करते हैं. बाहरी बैटरी और इलेक्ट्रॉनिक्स कमियां सहित, लेकिन अतिरिक्त वजन जोड़ने तक ही सीमित नहीं, बाइक पर भंडारण स्थान लेने वाली है, नकारात्मक बाइक पर वजन के वितरण को प्रभावित करने, और साइकिल डिजाइन के सौंदर्यशास्त्र को आहत किया है.

बिजली साइकिल आम तौर पर खाते में साइकिल की गति और त्वरण की निरंतरता नहीं लेते के लिए इसके अलावा, अप्रत्याशित और / या जरूरत से ज्यादा सशक्त हो सकता है और उस सवार की सुरक्षा से समझौता हो सकता है कि बिजली की मोटर से बिजली के फटने, जिसके परिणामस्वरूप एल्गोरिदम बिजली सहायता मौजूदा या भोग साइकिल की सवारी करते हैं. तदनुसार, बिजली साइकिल में सुधार बेहतर बैटरी और इलेक्ट्रॉनिक्स विन्यास और बेहतर बिजली सहायता एल्गोरिदम सहित आवश्यक हैं.

सारांश

वर्तमान शिक्षाओं एक इलेक्ट्रिक साइकिल और बैटरी या फ्रेम में से एक या अधिक ट्यूबों में संग्रहीत एक बैटरी पैक सहित बिजली साइकिल फ्रेम के पहलुओं का खुलासा. कुछ मामलों में, शीर्ष ट्यूब की एक जोड़ी साइकिल सीट ट्यूब के चरम का विस्तार, और एक इलेक्ट्रॉनिक्स आवास शीर्ष ट्यूब अंश विस्तार चरम बीच निपटारया जा सकता है. वैकल्पिक रूप से या इसके अतिरिक्त, एक हटायें नीचे बैकेट खोल हिस्से और एक हटायें नीचे बैकेट डालने नीचे ट्यूब और / या फ्रेम की सीट ट्यूब के भीतरी भागों के लिए सुविधाजनक उपयोग की अनुमति प्रदान की जा सकती है. एक बैटरी पैक और / या एक बैटरी इलेक्ट्रॉनिक्स प्रबंधन इकाई सुविधाजनक स्थान पर एक या नीचे ट्यूब और सीट ट्यूब के दोनों भीतर निपटारया जा सकता है.

चित्र का संक्षिप्त विवरण

अंजीर. 1 वर्तमान शिक्षाओं के पहलुओं के अनुसार, एक इलेक्ट्रिक साइकिल की एक ओर elevational दृश्य है.

अंजीर. 2 अंजीर के बिजली साइकिल की एक isometric दृश्य है. 1.



Alternative machine translation: (microsoft)

# Google translate

पीसीटी Biblio. तिथि विवरण दावा राष्ट्रीय चरण नोटिस चित्र दस्तावेज़

नोट: स्वतः ऑप्टिकल कैरेक्टर मान्यता प्रक्रियाओं पर आधारित पाठ. कानूनी मामलों के लिए पीडीएफ संस्करण का उपयोग करें

Hindi



Alternative machine translation: (microsoft)

Powered by Google Translate

विद्युत साइकिल

संबंधित आवेदन को पार संदर्भ

अमेरिका पेटेंट आवेदन सीरियल नं. इस आवेदन का दावा प्राथमिकता एतद्वारा संदर्भ द्वारा शामिल कर रहे हैं जो 1 अप्रैल 2013, दायर की 24 सितंबर, 2012 दायर / 625666 13, और / 854771 13.

पृष्ठभूमि

परम्परागत बिजली साइकिल आमतौर पर साइकिल फ्रेम के बाहर करने के लिए विभिन्न तरीकों से जुड़े होते हैं कि एक या एक से अधिक housings में शामिल एक बैटरी पैक और इलेक्ट्रॉनिक्स पर भरोसा करते हैं. बाहरी बैटरी और इलेक्ट्रॉनिक्स कमियां सहित, लेकिन अतिरिक्त वजन जोड़ने तक ही सीमित नहीं, बाइक पर भंडारण स्थान लेने वाली है, नकारात्मक बाइक पर वजन के वितरण को प्रभावित करने, और साइकिल डिजाइन के सौंदर्यशास्त्र को आहत किया है.

बिजली साइकिल आम तौर पर खाते में साइकिल की गति अं सशक्त हो सकता है और उस सवार की सुरक्षा से समझौता। सहायता मौजूदा या भोग साइकिल की सवारी करते हैं. तदनुसार सहायता एल्गोरिदम सहित आवश्यक हैं.

सारांश

वर्तमान शिक्षाओं एक इलेक्ट्रिक साइकिल और बैटरी या फ्रेम का खुलासा. कुछ मामलों में, शीर्ष ट्यूब की एक जोड़ी साइकिल बीच निपटारा जा सकता है. वैकल्पिक रूप से या इसके अतिरि की सीट ट्यूब के भीतरी भागों के लिए सुविधाजनक उपयोग की अनुमति प्रदान की जा सकती है. एक बैटरी पैक और / या एक बैटरी इलेक्ट्रॉनिक्स प्रबंधन इकाई सुविधाजनक स्थान पर एक या नीचे ट्यूब और सीट ट्यूब के दोनों भीतर निपटारा जा सकता है.



Original text

External batteries and electronics have drawbacks including, but not limited to, adding extra weight, consuming storage space on the bike, negatively affecting the distribution of weight on the bike, and hurting the aesthetics of the bicycle design.

[Contribute a better translation](#)

दा  
ली

ओं  
म  
। फ्रेम

# Information on National Phase Entries



**39. (WO2000040456) AUTOMATIC TRANSMISSION FOR ELECTRIC BICYCLE**

[PCT Biblio. Data](#) | 
 [Description](#) | 
 [Claims](#) | 
 [National Phase](#) | 
 [Notices](#) | 
 [Documents](#)

Available information on National Phase entries([more information](#))

Office	Entry Date	National Number	National Status
Australia	07.08.2001	<a href="#">10818/00</a>	
Canada	27.06.2001	<a href="#">2356932</a>	
China	20.07.2001	<a href="#">99815764.3</a>	
European Patent Office (EPO)	06.08.2001	<a href="#">1999954479</a>	Published: 17.10.2001 Withdrawn: 12.12.2003
Japan	06.07.2001	<a href="#">2000592179</a>	
Singapore		<a href="#">2001039197</a>	

# Information on PCT documents

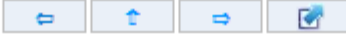

**42. (WO2001015966) BELT DRIVE SYSTEM FOR ELECTRIC BICYCLE**

[PCT Biblio. Data](#) | 
 [Description](#) | 
 [Claims](#) | 
 [National Phase](#) | 
 [Notices](#) | 
 [Documents](#)

International Application Status 			
Date	Title	View	Download
07.04.2013	International Application Status Report	<a href="#">HTML</a> , <a href="#">PDF</a>	<a href="#">PDF</a> , <a href="#">XML</a>
Published International Application			
Date	Title	View	Download
08.03.2001	Initial Publication without ISR (A2 10/2001)	<a href="#">PDF (14p.)</a>	<a href="#">PDF (14p.)</a> , <a href="#">ZIP(XML + TIFFs)</a>
30.08.2001	Later publication of international search report (A3 35/2001)	<a href="#">PDF (4p.)</a>	<a href="#">PDF (4p.)</a> , <a href="#">ZIP(XML + TIFFs)</a>
Related Documents on file at the International Bureau			
Date	Title	View	Download
08.03.2001	CA 2,283,547 01.09.1999 (Pr. Doc.)	<a href="#">PDF (16p.)</a>	<a href="#">PDF (16p.)</a> , <a href="#">ZIP(XML + TIFFs)</a>

# PATENTSCOPE CLIR\*

- ▶ Free tool available at <http://patentscope.wipo.int/search/clir/clir.jsp?interfaceLanguage=en>
- ▶ Enter a search query in either EN, DE, ES, FR, JP, RU, ZH, PT, IT, DU, SE and it will be expanded into the other languages (keywords translation)
- ▶ Built from bilingual dictionaries extracted statistically from Patent corpuses without supervision

**(\*) PATENTSCOPE CLIR: An empirical approach to applying SMT techniques to Cross Language Information Retrieval in the patent domain, C. Mazenc in Asian-Pacific Association for Machine Translation Journal Nr 51, June 2012**

# CLIR (Cross lingual Information Retrieval)

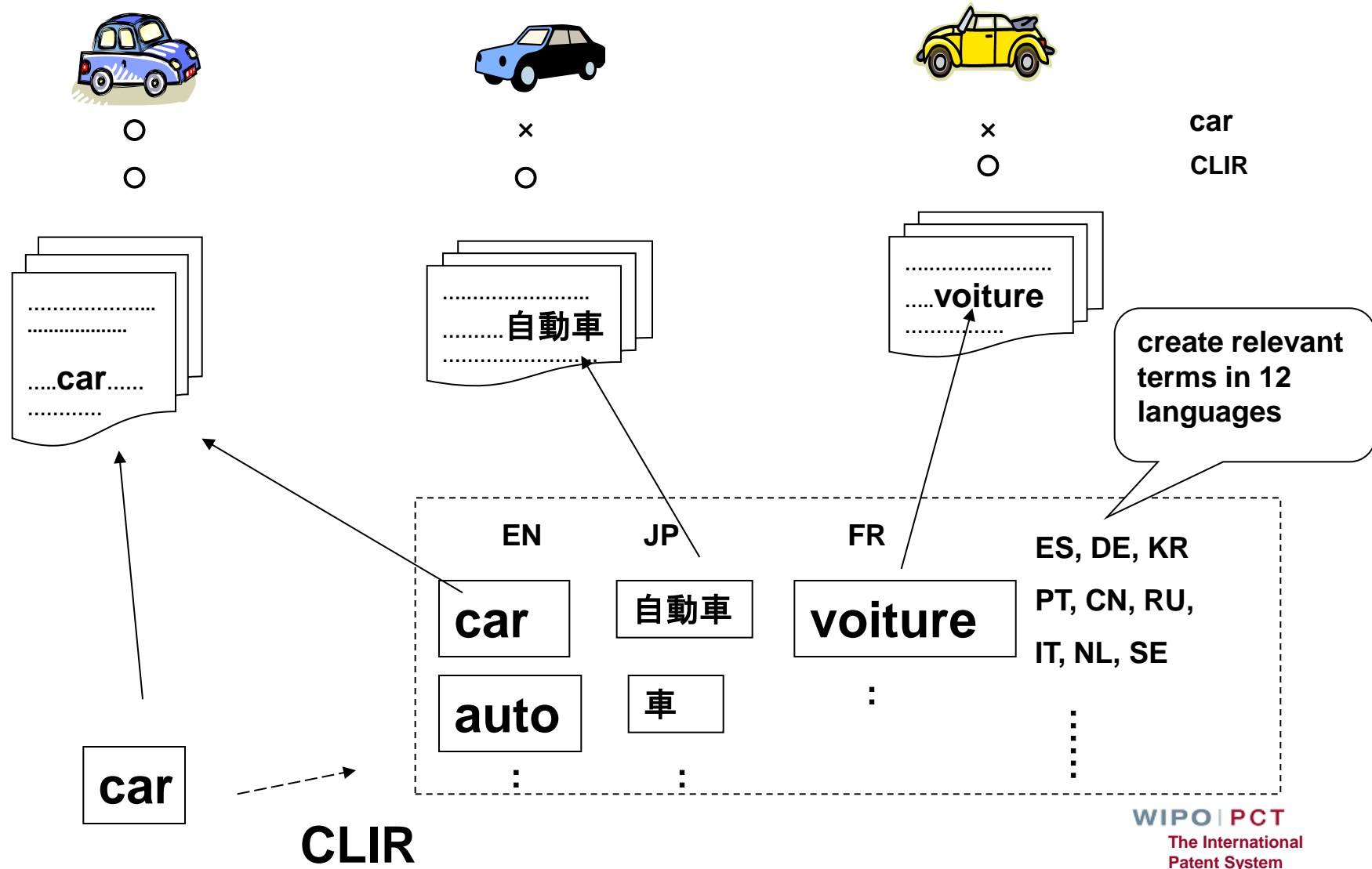

# Interface : Cross-lingual (CLIR)- Automatic



[Deutsch](#) | [English](#) | [Español](#) | [Français](#) | [日本語](#) | [한국어](#) | [Português](#) | [Русский](#) | [中文](#)

Search International and National Patent Applications: CLIR

[Home](#) > [IP Services](#) > [PATENTSCOPE](#) > [Back to PATENTSCOPE](#)

Input search terms

Query

[\[Help\]](#)

solar power

» Query Language:

» Expansion Mode:

» Precision  Recall



## PATENTSCOPE

Search International and National Patent Collections

WORLD INTELLECTUAL PROPERTY ORGANIZATION

Search | Browse | Translate | Options | News | Login | Help

Home > IP Services > PATENTSCOPE

Results 1-10 of 9,430 for Criteria: (EN\_Ti:("solar power" OR "solar energy" OR "solar supply"~21) OR EN\_AB:("solar power" OR "solar energy" OR "solar supply"~21)) OR (DE\_Ti:("Sonnenenergie" OR "Solarenergie") OR DE\_AB:("Sonnenenergie" OR "Solarenergie")) OR (ES\_Ti:("energía solar") OR ES\_AB:("energía solar")) OR (FR\_Ti:("énergie solaire") OR FR\_AB:("énergie solaire")) OR (JA\_Ti:("太陽光" OR "太陽電池光" OR "太陽電力" OR "太陽発電" OR "太陽光発電") OR JA\_AB:("太陽光" OR "太陽電池光" OR "太陽電力" OR "太陽発電" OR "太陽光発電")) OR (KO\_Ti:("태양에너지" OR "이용한 태양광 발전" OR "태양 광 발전" OR "태양광 에너지" OR "태양열을 이용한") OR KO\_AB:("태양에너지" OR "이용한 태양광 발전" OR "태양 광 발전" OR "태양광 에너지" OR "태양열을 이용한")) OR (PT\_Ti:("potência solar"~22 OR "energia solar"~22 OR "força solar"~22 OR "suprimento solar"~22 OR "alimentação solar"~22 OR "abastecimento solar"~22 OR "energia luminosa" OR "fonte solar"~22) OR PT\_AB:("potência solar"~22 OR "energia solar"~22 OR "força solar"~22 OR "suprimento solar"~22 OR "alimentação solar"~22 OR "abastecimento solar"~22 OR "energia luminosa" OR "fonte solar"~22)) OR (RU\_Ti:("гелиоэнергетической" OR "концентрирования солнечной энергии" OR "солнечным" OR "солнечная энергетическая" OR "солнечной энергии в переменный" OR "солнечной энергии и" OR "энергии солнца" OR "солнечной энергетической установки") OR RU\_AB:("гелиоэнергетической" OR "концентрирования солнечной энергии" OR "солнечным" OR "солнечная энергетическая" OR "солнечной энергии в переменный" OR "солнечной энергии и" OR "энергии солнца" OR "солнечной энергетической установки")) OR (ZH\_Ti:("太阳" OR "太阳能") OR ZH\_AB:("太阳" OR "太阳能")) Office(s):all Language:EN Stemming: true

prev

1

2

3

4

5

6

7

8

9

10

next

Page: 1 / 944 [Go >](#)

Refine Search

(EN\_Ti:("solar power" OR "solar energy" OR "solar supply"~21) OR EN\_AB:("solar power" OR "solar energy" OR "solar supply"~21)) OR (DE\_Ti:("Sonnenenergie" OR "Solarenergie") OR DE\_AB:("Sonnenenergie" OR "Solarenergie")) OR (ES\_Ti:("energía solar") OR ES\_AB:("energía solar")) OR (FR\_Ti:("énergie solaire") OR FR\_AB:("énergie solaire")) OR (JA\_Ti:("太陽光" OR "太陽電池光" OR "太陽電力" OR "太陽発電" OR "太陽光発電") OR JA\_AB:("太陽光" OR "太陽電池光" OR "太陽電力" OR "太陽発電" OR "太陽光発電")) OR (KO\_Ti:("태양에너지" OR "이용한 태양광 발전" OR "태양 광 발전" OR "태양광 에너지" OR "태양열을 이용한") OR KO\_AB:("태양에너지" OR "이용한 태양광 발전" OR "태양 광 발전" OR "태양광 에너지" OR "태양열을 이용한")) OR (PT\_Ti:("potência solar"~22 OR "energia solar"~22 OR "força solar"~22 OR "suprimento solar"~22 OR "alimentação solar"~22 OR "abastecimento solar"~22 OR "energia luminosa" OR "fonte solar"~22) OR PT\_AB:("potência solar"~22 OR "energia solar"~22 OR "força solar"~22 OR "suprimento solar"~22 OR "alimentação solar"~22 OR "abastecimento solar"~22 OR "energia luminosa" OR "fonte solar"~22)) OR (RU\_Ti:("гелиоэнергетической" OR "концентрирования солнечной энергии" OR "солнечным" OR "солнечная энергетическая" OR "солнечной энергии в переменный" OR "солнечной энергии и" OR "энергии солнца" OR "солнечной энергетической установки") OR RU\_AB:("гелиоэнергетической" OR "концентрирования солнечной энергии" OR "солнечным" OR "солнечная энергетическая" OR "солнечной энергии в переменный" OR "солнечной энергии и" OR "энергии солнца" OR "солнечной энергетической установки")) OR (ZH\_Ti:("太阳" OR "太阳能") OR ZH\_AB:("太阳" OR "太阳能"))

Search



Query Tree



PCT Biblio. Data

Full Text

National Phase

Notices

Documents

## Latest bibliographic data on file with the International Bureau



**Pub. No.:** WO/2010/150692      **International Application No.:** PCT/JP2010/060236

**Publication Date:** 29.12.2010      **International Filing Date:** 16.06.2010

**IPC:** *H01L 31/04* (2006.01), *H01L 31/042* (2006.01)

**Applicants:** TORAY ENGINEERING CO., LTD. [JP/JP]; Nihonbashi Muromachi Bldg., 3-16, Nihonbashi Hongokucho 3-chome, Chuo-ku, Tokyo 1030021 (JP) *(For All Designated States Except US)*.

YAMASHITA Masamichi [JP/JP]; (JP) *(For US Only)*.

IWADE Takashi [JP/JP]; (JP) *(For US Only)*.

TERADA Toyoharu [JP/JP]; (JP) *(For US Only)*.

FUJIMOTO Takayoshi [JP/JP]; (JP) *(For US Only)*

**Inventors:** YAMASHITA Masamichi; (JP).

IWADE Takashi; (JP).

TERADA Toyoharu; (JP).

FUJIMOTO Takayoshi; (JP)

**Agent:** HIROKOH Masaki; Tatsuno Nishi-Tenma Bldg., 1-6, Nishi-Tenma 3-chome, Kita-ku, Osaka-shi, Osaka 5300047 (JP)

**Priority Data:** 2009-149170 23.06.2009 JP

**Title**  
**(EN)** SOLAR BATTERY  
**(FR)** PILE SOLAIRE  
**(JA)** 太陽電池

**Abstract:** **(EN)** A solar battery module is configured so that a solar battery cell comprised of a transparent electrode, a light emitting element, and a backside electrode is formed on a substrate, and is sealed by a plastic material such as EVA. The solar battery module solves the problem that water enters through a gap between the substrate and a plastic



# Interface : Cross-lingual (CLIR)- Supervised



Deutsch | English | Español | Français | 日本語 | 한국어 | Português | Русский | 中文 |

Search International and National Patent Applications: CLIR

Home > IP Services > PATENTSCOPE > **Back to PATENTSCOPE**

Input search terms

Query

[Help]

solar power

» Query Language: English

» Expansion Mode: Supervised

Automatic

Supervised

» Precision  Recall

Next

# CLIR: precision vs recall



**Precision = Exactness or fidelity**  
Everything returned is relevant



Not all relevant items might have been found



**Recall = Completeness**  
All is included, nothing is missed



A lot of useless results could be returned  
Sorting is necessary

# CLIR – supervise mode – choice of technology domains



Deutsch | English | Español | Français | 日本語 | 한국어 | Português | Русский | 中文 |

**PATENTSCOPE**

Search International and National Patent Applications: CLIR

Home > IP Services > PATENTSCOPE > Back to PATENTSCOPE

Input search terms

Query Domains [ELEC,ENGY] [Help]

<p>[ADMN] Admin, Business, Management &amp; Soc Sci          [AERO] Aeronautics &amp; Aerospace Engineering          [AGRI] Agriculture, Fisheries &amp; Forestry          [AUDV] Audio, Audiovisual, Image &amp; Video Tech          [AUTO] Automotive &amp; Road Vehicle Engineering          [BLDG] Civil Engineering &amp; Building Construction          [CHEM] Chemical &amp; Materials Technology          [DATA] Computer Sci, Telecom &amp; Broadcasting          [ENVR] Environmental &amp; Safety Engineering          [FOOD] Foods &amp; Food Technology          [GENR] Generalities, Language, Media &amp; Info Sci          [HOME] Home Contents &amp; Household Maintenance          [HORO] Precision Mechanics, Jewelry &amp; Horology          [MANU] Manufacturing &amp; Materials Handling Tech          [MAR] Marine Engineering          [MEAS] Standards, Units, Metrology &amp; Testing          [MECH] Mechanical Engineering          [MED] Medical Technology          [METL] Metallurgy          [MIL] Military Technology          [MINE] Mining, Oil &amp; Gas Extraction &amp; Minerals          [NANO] Nano Technology          [PACK] Packaging &amp; Distribution of Goods          [PRNT] Printing &amp; Paper          [RAIL] Railway Engineering          [SCIE] Optical Engineering          [SPRT] Sports, Leisure, Tourism &amp; Hospitality Ind          [TEXT] Textile &amp; Clothing Industries          [TRAN] Transportation</p>	<p>Add ▶▶</p> <p>◀◀ Remove</p>	<p>[ELEC] Electrical Engineering &amp; Electronics          [ENGY] Energy, Fuels &amp; Heat Transfer Eng</p>
---	--------------------------------	--

Expand Synonyms ▶

**WIPO | PCT**  
 The International  
 Patent System

# CLIR – supervise mode – choice of terms

Input search terms

Term 1: solar

Term 2: power

Term 3: solar power

Variants Domains [ELEC,ENGY] [Help]

» Keep term untranslated when expanding query in other languages

» Less  More

solar energy  solar electricity  solar energy  solar cells

solar plant  solar array  solar collector  solar assembly

solar electric power  solar energy transformation

solar installation  solar electricity generation

solar radiation  solar energy generator  solar setup

solar facility  solar system  use a carrier  solar energy generator

solar unit  sunlight power generation  solar energy generation

solar apparatus  solar heating installation

solar energy system  solar cell fabrication

solar energy production  solar equipment

Add Variant +

Translate Selected Terms Start Over

# CLIR – Supervised mode – adjustment of terms and IPC

The image illustrates the process of adjusting search terms and IPC in a CLIR interface across multiple overlapping windows. Each window shows a set of language selection buttons and a search term field.

**Window 1 (Top):** Language buttons: English, German, Spanish, French, Japanese, Korean, Portuguese, Russian, Chinese, Italian, Swedish, Dutch, IPC. IPC Filter: [empty]. Domains: [ELEC.ENG].

**Window 2:** Language buttons: English, German, Spanish (selected), French, Japanese, Korean, Portuguese, Russian, Chinese, Italian, Swedish, Dutch, IPC. IPC Filter: B01B OR OR F23 C OR H01 C. Domains: [empty]. Search terms: "energía solar" OR "células solares" OR "celdas solares" OR "eléctrica solar" OR "energía eléctrica solar".

**Window 3:** Language buttons: English, German, Spanish, French (selected), Japanese, Korean, Portuguese, Russian, Chinese, Italian, Swedish, Dutch, IPC. IPC Filter: [empty]. Domains: [empty]. Search terms: "cellules solaires" OR "énergie solaire" OR "piles solaires" OR "photopiles" OR "énergie solaire" OR "alimentation solaire" OR "installation solaire" OR "courant solaire" OR "électrique solaire" OR "centrale électrique solaire" OR "énergie".

**Window 4:** Language buttons: English, German (selected), Spanish, French, Japanese, Korean, Portuguese, Russian, Chinese, Italian, Swedish, Dutch, IPC. IPC Filter: [empty]. Domains: [empty]. Search terms: "Solarzellen" OR "Solarenergie" OR "Sonnenenergie" OR "Solaranlage".

**Window 5 (Bottom):** Language buttons: English (selected), German, Spanish, French, Japanese, Korean, Portuguese, Russian, Chinese, Italian, Swedish, Dutch, IPC. IPC Filter: [empty]. Domains: [empty]. Search terms: "solar power" OR "solar cells" OR "solar electric power" OR "solar energy" OR "solar plant".

PCT Biblio. Data

Full Text

National Phase

Notices

Documents

## Latest bibliographic data on file with the International Bureau



**Pub. No.:** WO/2010/150692      **International Application No.:** PCT/JP2010/060236

**Publication Date:** 29.12.2010      **International Filing Date:** 16.06.2010

**IPC:** *H01L 31/04* (2006.01), *H01L 31/042* (2006.01)

**Applicants:** TORAY ENGINEERING CO., LTD. [JP/JP]; Nihonbashi Muromachi Bldg., 3-16, Nihonbashi Hongokucho 3-chome, Chuo-ku, Tokyo 1030021 (JP) *(For All Designated States Except US)*.

YAMASHITA Masamichi [JP/JP]; (JP) *(For US Only)*.

IWADE Takashi [JP/JP]; (JP) *(For US Only)*.

TERADA Toyoharu [JP/JP]; (JP) *(For US Only)*.

FUJIMOTO Takayoshi [JP/JP]; (JP) *(For US Only)*

**Inventors:** YAMASHITA Masamichi; (JP).

IWADE Takashi; (JP).

TERADA Toyoharu; (JP).

FUJIMOTO Takayoshi; (JP)

**Agent:** HIROKOH Masaki; Tatsuno Nishi-Tenma Bldg., 1-6, Nishi-Tenma 3-chome, Kita-ku, Osaka-shi, Osaka 5300047 (JP)

**Priority Data:** 2009-149170 23.06.2009 JP

**Title**  
**(EN)** SOLAR BATTERY  
**(FR)** PILE SOLAIRE  
**(JA)** 太陽電池

**Abstract:** **(EN)** A solar battery module is configured so that a solar battery cell comprised of a transparent electrode, a light emitting element, and a backside electrode is formed on a substrate, and is sealed by a plastic material such as EVA. The solar battery module solves the problem that water enters through a gap between the substrate and a plastic



# Examples of accessing to the PCT Products

PATENT COOPERATION TREATY		
PCT		
INTERNATIONAL SEARCH REPORT		
(PCT Article 18 and Rules 43 and 44)		
Applicant's or agent's file reference <b>PO8017</b>	<b>FOR FURTHER ACTION</b> <small>see Form PCT/ISA/220 as well as, where applicable, Item 5 below.</small>	
International application No. <b>PCT/EP2009/060890</b>	International filing date (day/month/year) <b>24/08/2009</b>	(Earliest) Priority Date (day/month/year) <b>25/08/2008</b>
Applicant <b>RATIOPHARM GMBH</b>		
<p>This international search report has been prepared by this International Searching Authority and is transmitted to the applicant according to Article 18. A copy is being transmitted to the International Bureau.</p> <p>This international search report consists of a total of <u>4</u> sheets.  <input checked="" type="checkbox"/> It is also accompanied by a copy of each prior art document cited in this report.</p>		
<p>1. <b>Basis of the report</b></p> <p>a. With regard to the <b>language</b>, the international search was carried out on the basis of:</p> <p><input checked="" type="checkbox"/> the international application in the language in which it was filed  <input type="checkbox"/> a translation of the international application into _____, which is the language of a translation furnished for the purposes of international search (Rules 12.5(a) and 23.1(b))</p> <p>b. <input type="checkbox"/> This international search report has been established taking into account the <b>rectification of an obvious mistake</b> authorized by or notified to this Authority under Rule 91 (Rule 43.604(a)).</p> <p>c. <input type="checkbox"/> With regard to any <b>nucleotide and/or amino acid sequence</b> disclosed in the international application, see Box No. I.</p> <p>2. <input type="checkbox"/> <b>Certain claims were found unsearchable</b> (See Box No. II)</p> <p>3. <input type="checkbox"/> <b>Unity of invention is lacking</b> (see Box No. III)</p> <p>4. With regard to the <b>title</b>,</p> <p><input checked="" type="checkbox"/> the text is approved as submitted by the applicant  <input type="checkbox"/> the text has been established by this Authority to read as follows:</p> <p>5. With regard to the <b>abstract</b>,</p> <p><input checked="" type="checkbox"/> the text is approved as submitted by the applicant  <input type="checkbox"/> the text has been established, according to Rule 38.2(b), by this Authority as it appears in Box No. IV. The applicant may, within one month from the date of mailing of this international search report, submit comments to this Authority</p> <p>6. With regard to the <b>drawings</b>,</p> <p>a. the figure of the drawings to be published with the abstract is Figure No. _____  <input type="checkbox"/> as suggested by the applicant  <input type="checkbox"/> as selected by this Authority, because the applicant failed to suggest a figure  <input type="checkbox"/> as selected by this Authority, because this figure better characterizes the invention</p> <p>b. <input checked="" type="checkbox"/> none of the figures is to be published with the abstract</p>		

Form PCT/ISA/210 (first sheet) (April 2007)



C. DOCUMENTS CONSIDERED TO BE RELEVANT		
Category*	Citation of document, with indication, where appropriate, of the relevant passages	Relevant to claim No.
A	<p>WO 2007/143483 A (SMITHKLINE BEECHAM CORP [US]; WHITEHEAD BONNIE F [US]; HO PETER T C [U] 13 December 2007 (2007-12-13) page 8, paragraph 3; table 1</p> <p>-----</p>	1-9
A	<p>WO 2006/113649 A (SMITHKLINE BEECHAM CORK LTD [IE]; CARTER BARRY HOWARD [US]; CAMPBELL D) 26 October 2006 (2006-10-26) cited in the application the whole document</p> <p>-----</p> <p style="text-align: center;">-/--</p>	1-9

Further documents are listed in the continuation of Box C.

See patent family annex.



## PATENTSCOPE

Mobile | Deutsch | Español | Français | 日本語 | 한국어 | Português | Русский | 中文 | العربية |

Search International and National Patent Collections

WORLD INTELLECTUAL PROPERTY ORGANIZATION

Search Browse Translate Options News Login Help

Simple

Advanced Search

Field Combination

Cross Lingual Expansion

Front Page

Office: All

Search

PCT Publication 35/2016 (2016/09/01) is now available. The next publication date is scheduled as follows: Gazette number 36/2016 (2016/09/09). [More](#)

**WIPO | PCT**  
The International  
Patent System



# PATENTSCOPE

Mobile | Deutsch | Español | Français | 日本語 | 한국어 | Português | Русский | 中文 | العربية

Search International and National Patent Collections

WORLD INTELLECTUAL PROPERTY ORGANIZATION

Search Browse Translate Options News Login Help

Home > IP Services > PATENTSCOPE

## Field Combination

Front Page	=		?
AND WIPO Publication Number	=	2007/143483	?
AND National Publication Number	=		?
AND Publication Date	=		?
AND English Title	=		?
AND English Abstract	=		?
AND Applicant Name	=		?
AND International Class	=		?
AND Inventor Name	=		?
AND Office Code	=		?
AND English Description	=		?
AND English Claims	=		?
AND Licensing availability	=	<input type="checkbox"/>	
AND Inventor Name	Is Empty:	<input checked="" type="radio"/> N/A <input type="radio"/> Yes <input type="radio"/> No	

Language English Stem:  Office: All Specify ⇌

1 results Search Reset

(+) Add another search field | (-) Reset search fields Tooltip Help



Machine translation

1. (WO2007143483) COMBINATION OF PAZOPANIB AND LAPATINIB FOR TREATING CANCER

PCT Biblio. Data	Description	Claims	National Phase	Notices	Drawings	Documents
Latest bibliographic data on file with the International Bureau <span style="float:right">PermaLink </span>						
Pub. No.:	<b>WO/2007/143483</b>	International Application No.: PCT/US2007/070032				
Publication Date:	13.12.2007	International Filing Date: 31.05.2007				
IPC:	A61K 31/506 (2006.01), A61K 31/517 (2006.01), A61K 45/06 (2006.01), A61P 35/00 (2006.01)					
Applicants:	SMITHKLINE BEECHAM CORPORATION [US/US]; One Franklin Plaza, P.O. Box 7929, Philadelphia, Pennsylvania 19101 (US) (For All Designated States Except US). WHITEHEAD, Bonnie F. [US/US]; (US) (For US Only). HO, Peter T.C. [US/US]; (US) (For US Only). SUTTLE, Albert Benjamin [US/US]; (US) (For US Only). PANDITE, Arundathy Nirmalini [US/US]; (US) (For US Only)					
Inventors:	WHITEHEAD, Bonnie F.; (US). HO, Peter T.C.; (US). SUTTLE, Albert Benjamin; (US). PANDITE, Arundathy Nirmalini; (US)					
Agent:	DADSWELL, Charles E.; Corporate Intellectual Property, Five Moore Drive, PO Box 13398, Research Triangle Park, NC 27709 (US)					
Priority Data:	60/803,659 01.06.2006 US					
Title	(EN) COMBINATION OF PAZOPANIB AND LAPATINIB FOR TREATING CANCER (FR) PROCÉDÉ DE TRAITEMENT DU CANCER					
Abstract:	(EN)The present invention relates to a method of treating cancer in a mammal by administration of pyrimidine derivatives and quinazoline derivatives. In particular, the method relates to a method of treating cancer by administration of 5-[[4-[(2,3-dimethyl-2H-indazol-6-yl)methylamino]-2-					



# PATENTSCOPE

Mobile | Deutsch | Español | Français | 日本語 | 한국어 | Português | Русский | 中文 | العربية |

Search International and National Patent Collections

WORLD INTELLECTUAL PROPERTY ORGANIZATION

Search Browse Translate Options News Login Help

Home > IP Services > PATENTSCOPE

Machine translation

## 1. (WO2007143483) COMBINATION OF PAZOPANIB AND LAPATINIB FOR TREATING CANCER

PCT Biblio. Data Description Claims National Phase Notices Drawings Documents

### International Application Status

Date	Title	View	Download
08.09.2016	International Application Status Report	HTML, PDF	PDF, XML

### Published International Application

Date	Title	View	Download
13.12.2007	Initial Publication without ISR (A2 50/2007)	PDF (49p.)	PDF (49p.), ZIP(XML + TIFFs)
07.02.2008	Later publication of international search report (A3 06/2008)	PDF (4p.)	PDF (4p.), ZIP(XML + TIFFs)
13.12.2007	Declaration	PDF (1p.)	PDF (1p.), ZIP(XML + TIFFs)
13.12.2007	Declaration	PDF (1p.)	PDF (1p.), ZIP(XML + TIFFs)
13.12.2007	Declaration	PDF (2p.)	PDF (2p.), ZIP(XML + TIFFs)

### Search and Examination-Related Documents

Date	Title	View	Download
03.12.2008	(IB/373) International Preliminary Report on Patentability Chapter I	PDF (6p.)	PDF (6p.), ZIP(XML + TIFFs)
01.12.2008	Written Opinion of the International Search Authority	PDF (5p.)	PDF (5p.), ZIP(XML + TIFFs)

(19) World Intellectual Property Organization  
International Bureau



(43) International Publication Date  
13 December 2007 (13.12.2007)

PCT

(10) International Publication Number  
**WO 2007/143483 A2**

(51) International Patent Classification:  
A61K 31/506 (2006.01) A61K 45/06 (2006.01)  
A61K 31/517 (2006.01) A61P 35/00 (2006.01)

(74) Agents: DADSWELL, Charles E. et al.; Corporate Intellectual Property, Five Moore Drive, PO Box 13398, Research Triangle Park, NC 27709 (US).

(21) International Application Number:  
PCT/US2007/070032

(80) Designated States (unless otherwise indicated, for every kind of national protection available): AE, AG, AL, AM, AT, AU, AZ, BA, BB, BG, BH, BR, BW, BY, BZ, CA, CH, CN, CO, CR, CU, CZ, DE, DK, DM, DO, DZ, EC, EG, ES, FI, GB, GD, GE, GH, GM, GT, HN, HR, HU, ID, IL, IN, IS, JP, KE, KG, KM, KN, KP, KR, KZ, LA, LC, LK, LR, LS, LT, LU, LY, MA, MD, ME, MG, MK, MN, MW, MX, MY, MZ, NA, NG, NI, NO, NZ, OM, PG, PH, PL, PT, RO, RS, RU, SC, SD, SE, SG, SK, SL, SM, SV, SY, TJ, TM, TN, TR, TT, TZ, UA, UG, US, UZ, VC, VN, ZA, ZM, ZW.

(22) International Filing Date: 31 May 2007 (31.05.2007)

(25) Filing Language: English

(26) Publication Language: English

(30) Priority Data:  
60603,659 1 June 2006 (01.06.2006) US

(84) Designated States (unless otherwise indicated, for every kind of regional protection available): ARIPO (BW, GH, GM, KE, LS, MW, MZ, NA, SD, SL, SZ, TZ, UG, ZM, ZW), Eurasian (AM, AZ, BY, KG, KZ, MD, RU, TJ, TM), European (AT, BE, BG, CH, CY, CZ, DE, DK, EE, ES, FI, FR, GB, GR, HU, IE, IS, IT, LT, LU, LV, MC, MT, NL, PL, PT, RO, SE, SI, SK, TR), OAPI (BF, BJ, CF, CG, CI, CM, GA, GN, GQ, GW, ML, MR, NI, SN, TD, TG).

(71) Applicant (for all designated States except US):  
SMITHKLINE BEECHAM CORPORATION  
[US/US]; One Franklin Plaza, PO. Box 7929, Philadelphia, Pennsylvania 19101 (US).

**Declarations under Rule 4.17:**

- as to applicant's entitlement to apply for and be granted a patent (Rule 4.17(i))
- as to the applicant's entitlement to claim the priority of the earlier application (Rule 4.17(ii))
- of inventorship (Rule 4.17(iii))

**Published:**

- without international search report and to be republished upon receipt of that report

For two-letter codes and other abbreviations, refer to the "Guidance Notes on Codes and Abbreviations" appearing at the beginning of each regular issue of the PCT Gazette.

(72) Inventors; and  
(73) Inventors/Applicants (for US only): WHITEHEAD, Bonnie F. [US/US]; GlaxoSmithKline, Corporate Intellectual Property Department, Five Moore Drive, PO Box 13398, Research Triangle Park, NC 27709 (US); BO, Peter E.C. [US/US]; GlaxoSmithKline, Corporate Intellectual Property Department, Five Moore Drive, PO Box 13398, Research Triangle Park, NC 27709 (US); SUTTLE, Albert Benjamin [US/US]; GlaxoSmithKline, Corporate Intellectual Property Department, Five Moore Drive, PO Box 13398, Research Triangle Park, NC 27709 (US); PANDITE, Arundathy Nirmalini [US/US]; GlaxoSmithKline, Corporate Intellectual Property Department, Five Moore Drive, PO Box 13398, Research Triangle Park, NC 27709 (US).

(54) Title: CANCER TREATMENT METHOD

(57) Abstract: The present invention relates to a method of treating cancer in a mammal by administration of pyrimidine derivatives and quinazoline derivatives. In particular, the method relates to a method of treating cancer by administration of 5-[4-[(2,3-dimethyl-2H-indazol-4-yl)methylamino]-2-pyrimidinyl]amino]-2-methylbenzenesulfonamide or salts or solvates thereof, and N-[3-chloro-4-[[3-fluorobenzoyloxy]phenyl]-6-[5-[[[2-(methanesulphonylthio)amino]methyl]-2-furyl]-4-quinazolinamine, or salts or solvates thereof.



WO 2007/143483 A2

## B

tannate, tartrate, teoclate, tosylate, triethiodide, trimethylammonium and valerate. Other salts, which are not pharmaceutically acceptable, may be useful in the preparation of compounds of this invention and these form a further aspect of the invention.

While it is possible that, for use in the cancer treatment methods of the present invention, compounds of formula (I) and formula (II) as well as salts or solvates thereof may be administered as the raw chemicals, it is possible to present the active ingredients as pharmaceutical compositions. The pharmaceutical compositions include a compound of formula (I) or salts or solvates thereof, and one or more pharmaceutically acceptable carriers, diluents, or excipients, or a compound of formula (II) or salts or solvates thereof, and one or more pharmaceutically acceptable carriers, diluents, or excipients. Additionally, the pharmaceutical composition may include a compounds of formula (I) and formula (II), or salts or solvates thereof, and one or more pharmaceutically acceptable carriers, diluents, or excipients. The carrier(s), diluent(s) or excipient(s) must be acceptable in the sense of being compatible with the other ingredients of the formulation and not deleterious to the recipient thereof.

Pharmaceutical formulations may be presented in unit dose forms containing a predetermined amount of active ingredient per unit dose. Such a unit may contain, for example, 0.5mg to 1g, preferably 10mg to 500mg, of a compound of formula (I) or formula (II), or 0.5mg to 1g, preferably 10mg to 500mg of each compound of formula (I) and formula (II) wherein the compounds are in a single unit dose. The contents of each unit dose may depend on the condition being treated, the route of administration and the age, weight and condition of the patient, or pharmaceutical formulations may be presented in unit dose forms containing a predetermined amount of active ingredient per unit dose. Preferred unit dosage formulations are those containing a daily dose or sub-dose, as herein above recited, or an appropriate fraction thereof, of an active ingredient. Furthermore, such pharmaceutical formulations may be prepared by any of the methods well known in the pharmacy art.

The compounds of formula (I) and formula (II) may be administered by any appropriate route. Suitable routes include oral, rectal, nasal, topical (including buccal and sublingual), vaginal, and parenteral (including subcutaneous, intramuscular, intravenous, intradermal, intrathecal, and epidural). It will be appreciated that the

**Biological Data****Example 3:*****Clinical Study of Orally Administered pazopanib and lapatinib in Patients with Solid Tumors***

Fifty-three patients with various types of tumors were treated with pazopanib and lapatinib once daily. The amount of pazopanib and lapatinib administered to the patients is summarized below in Table 1. Each treatment period was twenty one (21) days, and treatment continued until unacceptable toxicities or disease progression occurred, or treatment was delayed greater than three weeks. Clinical response was determined every three cycles, and was determined by response evaluation criteria in solid tumors (RECIST) guidelines. Safety and pharmacodynamics were separately assessed.

**Table 1**

Lapatinib (mg/day)	Pazopanib (mg/day)	Number of Subjects
750	250	4
750	500	6
1000	250	3
1000	400	2
1000	500	4
1250	250	6
1250	400	7
1500	200	3
1000	400	18

Preliminary representative patient data for some patients showing clinical benefit are shown below in Table 2. The median study duration for the subset of patients shown below was 24 weeks. Of the 17 shown, 11 were on the study for greater than 24 weeks. Prolonged stable disease (SD) was observed in 14 of the 17, and partial remission (PR) was observed in the remaining 3.



# Espacenet



**Espacenet**  
Patent search

Deutsch English Français  
Contact  
Change country ▼

◀ About Espacenet Other EPO online services ▼

Search Result list ★ My patents list (0) Query history Settings Help

Smart search

**Advanced search**

Classification search

Quick help -

- [How many search terms can I enter per field?](#)
- [How do I enter words from the title or abstract?](#)
- [How do I enter words from the description or claims?](#)
- [Can I use truncation/wildcards?](#)
- [How do I enter publication, application, priority and NPL reference numbers?](#)
- [How do I enter the names of persons and organisations?](#)
- [What is the difference between the IPC and the CPC?](#)
- [What formats can I use for the publication date?](#)
- [How do I enter a date range for a publication date search?](#)
- [Can I save my query?](#)

Related links +

## Advanced search

Select the collection you want to search in ⓘ

Worldwide - collection of published applications from 90+ countries ▼

Enter your search terms - CTRL-ENTER expands the field you are in

Enter keywords

Title: ⓘ plastic and bicycle

Title or abstract: ⓘ hair

Enter numbers with or without country code

Publication number: ⓘ WO2008014520

WO2011152795

Application number: ⓘ DE201310112935

Priority number: ⓘ WO1995US15925



Europäisches Patentamt  
European Patent Office  
Office européen des brevets

**Espacenet**  
Patent search

Deutsch English Français

Contact

Change country ▼

◀ About Espacenet Other EPO online services ▼

Search

Result list

★ My patents list (0)

Query history

Settings

Help

[Refine search](#) → Results

Smart search

Advanced search

Classification search

Quick help

- [Can I subscribe to an RSS feed of the result list?](#)
- [What does the RSS reader do with the result list?](#)
- [Can I export my result list?](#)
- [What happens if I click on "Download covers"?](#)
- [Why is the number of results sometimes only approximate?](#)
- [Why is the list limited to 500 results?](#)
- [Can I deactivate the highlighting?](#)
- [Why is it that certain documents are sometimes not displayed in the result list?](#)
- [Can I sort the result list?](#)
- [What happens if I click on the star icon?](#)
- [What are XP documents?](#)
- [Can I save my query?](#)

## Result list

Select all (0/1)

Compact

Export ( CSV | XLS )

Download covers

Print

1 result found in the Worldwide database for:  
**WO2011152795** as the publication number

### 1. DEVICE AND METHOD FOR DRIVING LEDS



**Inventor:**

WEE KAI FOOK  
FRANCIS [SG]  
STONA ANDREA  
[IT]  
(+3)

**Applicant:**

OPULENT ELECTRONICS  
INTERNAT PTE LTD [SG]  
WEE KAI FOOK FRANCIS [SG]  
(+4)

**CPC:**

[H02M2001/0012](#)  
[H02M2001/0022](#)  
[H02M3/33523](#)  
(+3)

**IPC:**

H02M1/00  
H05B37/02  
H05B43/02

**Publication info:**

**WO 2011152795** (A1)  
2011-12-08

**Priority date:**

2010-06-04

WO2011152795 (A1)

**Bibliographic data**

Description

Claims

Mosaics

Original document

Cited documents

Citing documents

INPADOC legal status

INPADOC patent family

**Quick help**

- [What is meant by high quality text as facsimile?](#)
- [What does A1, A2, A3 and B stand for after a European publication number?](#)
- [What happens if I click on "In my patents list"?](#)
- [What happens if I click on the "Register" button?](#)
- [Why are some sidebar options deactivated for certain documents?](#)

**Bibliographic data: WO2011152795 (A1) — 2011-12-08**

★ In my patents list ↗ EP Register 📄 Report data error 🖨️ Print

**DEVICE AND METHOD FOR DRIVING LEDS**

**Page bookmark** [WO2011152795 \(A1\) - DEVICE AND METHOD FOR DRIVING LEDS](#)

**Inventor(s):** WEE KAI FOOK FRANCIS [SG]; STONA ANDREA [IT]; GROPPI LEOPOLDO [IT]; MAN KWOK WING [CN]; CHONG FOO WING [MY] ±

**Applicant(s):** OPULENT ELECTRONICS INTERNAT PTE LTD [SG]; WEE KAI FOOK FRANCIS [SG]; STONA ANDREA [IT]; GROPPI LEOPOLDO [IT]; MAN KWOK WING [CN]; CHONG FOO WING [MY] ±

**Classification:**  
- international: [H02M1/00](#); [H05B37/02](#); [H05B43/02](#)  
- cooperative: [H02M3/33523](#); [H05B33/0815](#); [H05B33/0848](#); [H05B37/02](#); [H02M2001/0012](#); [H02M2001/0022](#)

**Application number:** WO2010SG00212 20100604

**Priority number(s):** WO2010SG00212 20100604

**Also published as:** → [ZA201109180 \(B\)](#) [US2013106304 \(A1\)](#) [US9084303 \(B2\)](#) [TW201204170 \(A\)](#) [TWI457036 \(B\)](#) [SG176544 \(A1\)](#) [JP2012526367 \(A\)](#) [JP5472871 \(B2\)](#) → [HK1173605 \(A1\)](#) [ES2460627 \(T3\)](#) [EP2589267 \(A1\)](#) → [EP2589267 \(A4\)](#) [EP2589267 \(B1\)](#) [DK2589267 \(T3\)](#) [CN102598866 \(A\)](#) [CN102598866 \(B\)](#) [CA2746380 \(A1\)](#) [CA2746380 \(C\)](#) [AU2010339630 \(A1\)](#) → [AU2010339630 \(A8\)](#) [AU2010339630 \(B2\)](#) → [less](#)



AU2010339630 (B2)

- Bibliographic data
- Description
- Claims
- Mosaics
- Original document**
- Cited documents
- Citing documents
- INPADOC legal status
- INPADOC patent family

Quick help —

- [What happens if I click on "In my patents list"?](#)
- [What happens if I click on the "Register" button?](#)
- [How can I maximise the page view?](#)
- [How can I download documents?](#)
- [Why is the Original document not available for certain documents?](#)

## Original document: AU2010339630 (B2) — 2013-07-11

★ In my patents list ↗ EP Register 🗑 Report data error

🖨 Print

### Device and method for driving LEDs

◀ Page 1/32 Bibliography ▶ Maximise Download

**(12) STANDARD PATENT**  
**(19) AUSTRALIAN PATENT OFFICE**

(11) Application No. **AU 2010339630 B2**

(54) Title  
**Device and method for driving LEDs**

(51) International Patent Classification(s)  
**H05B 37/02** (2006.01)

(21) Application No: **2010339630**

(22) Date of Filing: **2010.06.04**

(73) INVENTOR: **WO2011152795**

# WIPO-CASE

# WIPO CASE Service - Outline

## OPD

## WIPO CASE

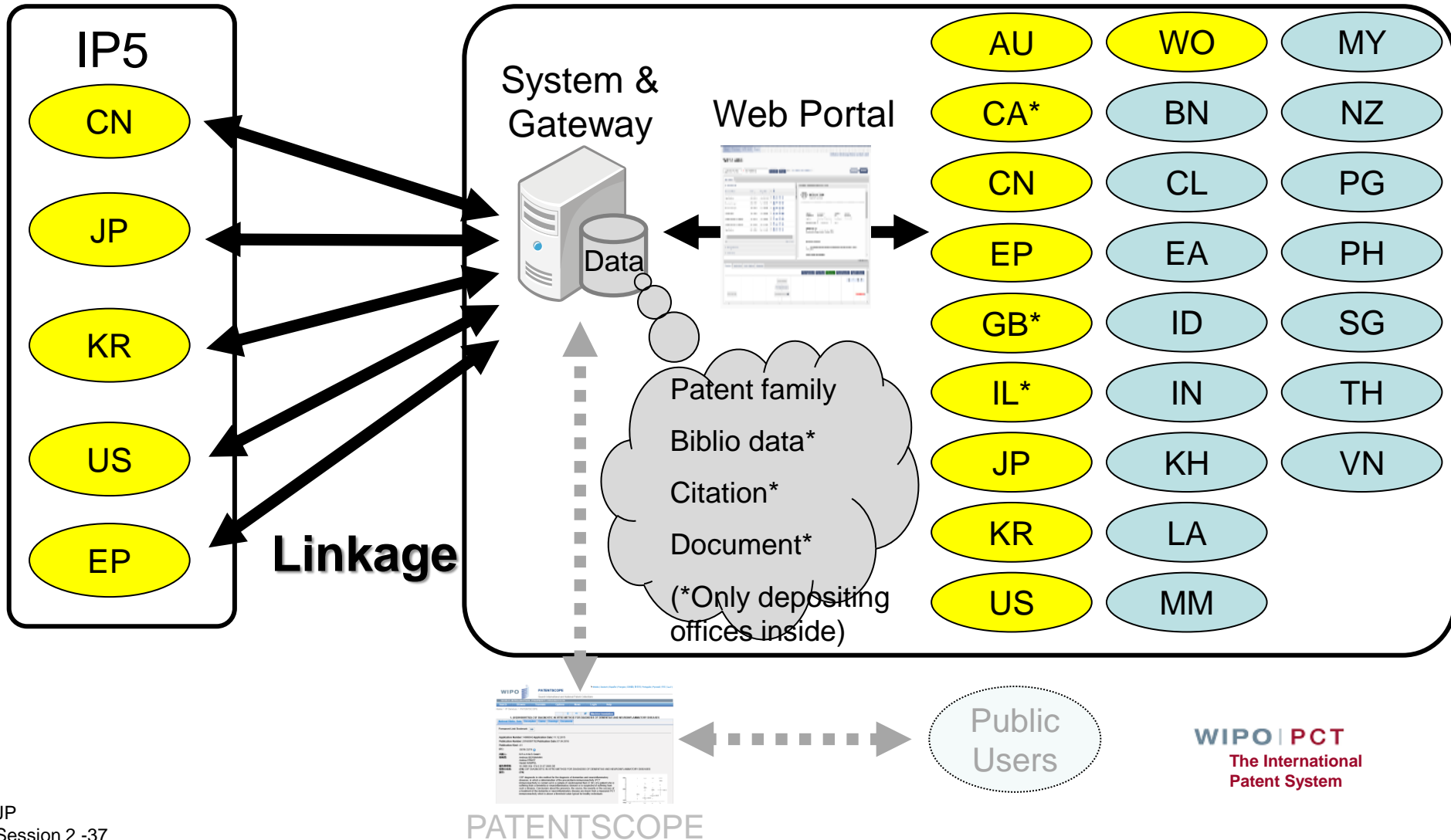

# WIPO CASE Service - Outline

- Who can use?
  - Examiners of participating offices
- When and where can you use?
  - Accessible on the Internet through authentication
- What can you use?
  - Patent family data
  - Bibliographic data
  - Documents (specification, examination results)
  - Citation (AU, CN, EP, GB, JP, KR, US)
- Why do you use?
  - Improve efficiency and quality of examination
- How do you use?
  - Number search (see User Guide at portal)

Printable and viewable Pdf file

# WIPO CASE Membership

Providing Offices	Notes
<b>AU (Australia)</b>	Available to public access
<b>CA (Canada)</b>	Available to public access
<b>CN (China)</b>	Available to public access
<b>EP (EPO)</b>	Available to public access
<b>GB (United Kingdom)</b>	
<b>IL (Israel)</b>	
<b>JP (Japan)</b>	Available to public access
<b>KR (Republic of Korea)</b>	Available to public access
<b>US (United States of America)</b>	
<b>WO (WIPO IB (PCT))</b>	Providing office only, for PCT documentation Available to public access

Accessing-only Offices	Notes
<b>BN (Brunei Darussalam)</b>	Not yet active as a providing office
<b>CL (Chile)</b>	Will become providing office when technically ready.
<b>EA (EAPO)</b>	
<b>ID (Indonesia)</b>	
<b>IN (India)</b>	
<b>KH (Cambodia)</b>	
<b>LA (Lao PDR)</b>	
<b>MN (Mongolia)</b>	
<b>MY (Malaysia)</b>	
<b>NZ (New Zealand)</b>	Indicated willingness to become a providing office.
<b>PG (Papua New Guinea)</b>	
<b>PH (Philippines)</b>	
<b>SG (Singapore)</b>	
<b>TH (Thailand)</b>	
<b>VN (Viet Nam)</b>	



# Usage of WIPO CASE

- Period: March. 2015 – March. 2016
- Total: 17,099 (based on Counts of Accessed Documents)
- Statistics

Accessing Office	Usage	
	Count	Percentage of Total
JP	10,068	59%
GB	1,568	9.2%
PH	1,482	8.7%
MY	1,254	7.3%
AU	854	5.0%
CA	702	4.1%
CN	518	3.0%
ID	206	1.2%
KR	180	1.1%
IL	151	0.9%

Trend of Usage

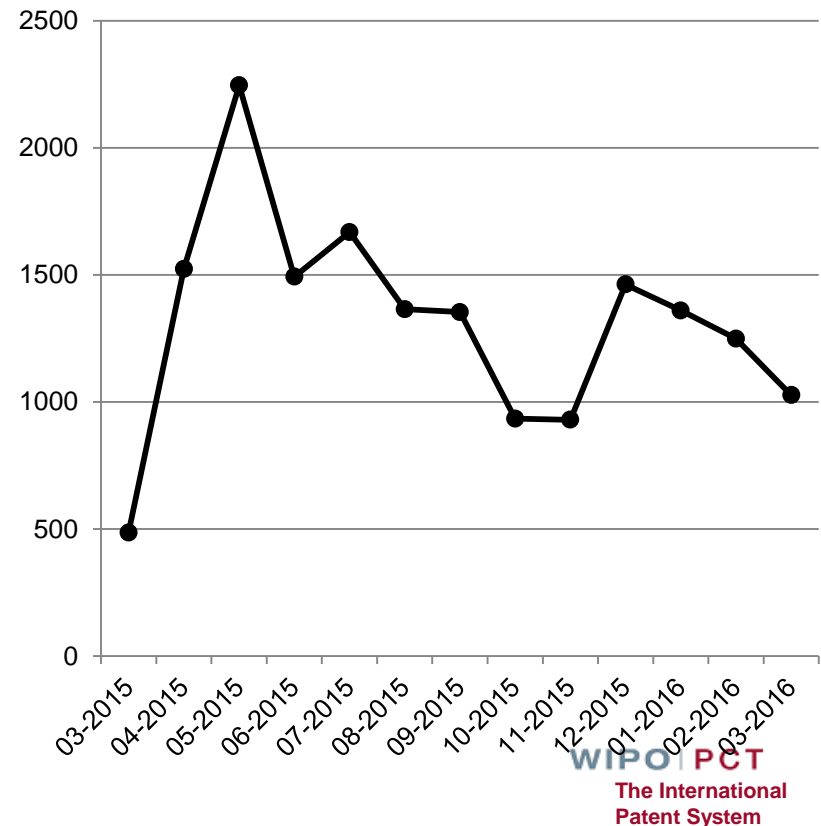

# WIPO CASE Service – Patent Family

## ■ Patent Family Data

- ❑ National applications and PCT applications
  - Application (numbers and dates)
  - Publication (numbers, kind codes and dates)
  - Priority application (numbers and dates)
  - National phase entry application (numbers and dates)
- ❑ Covered with AU, CA, CL, CN, EA, GB, ID, IL, JP, KR, MY, PH, SG, TH, VN, US, WO(PCT)
- ❑ Data coverage information updated daily

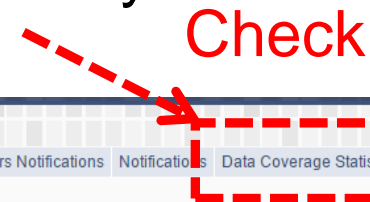

Check

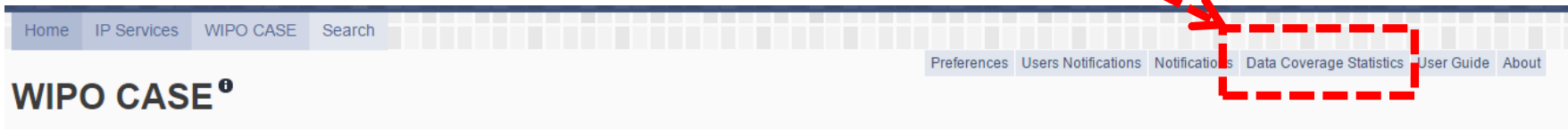

WIPO CASE<sup>®</sup>

# WIPO CASE Service – Patent Family

Application	Priorities					
A1				P1		
A2				P1	P2	
A3				P1	P2	
A4					P2	P3
A5						P3
A6	A1					
A7		A5	A6			

## ■ Simple search

One level backward and then one level forward

## ■ Extended search

All sets of applications related by priority or national phase entry

# WIPO CASE Service – Document Data

Office	AU*	CA	CN*	EP	GB*	IL	JP*	KR*	US*	IB
Applications published since	Jan 1, 2006	Jan 1, 2008			Jan 1, 2008					Jan 1, 1978
Published applications that are filed on and after	█	█	Feb 10, 2010		█	Jan 1, 2010	Dec 1, 1990	Jan 1, 1999	Jan 1, 2003	█
Specifications and Incoming Documents (e.g. claims, amendment)	Yes	Yes	Yes	Yes	Yes	Yes	Yes	Yes	Yes	Yes
Outgoing Documents (e.g. examination document)	Yes	Yes	Yes**	Yes	Yes	Yes**	Yes**	Yes**	Yes	Yes**

# WIPO CASE Service – Document Data

Office	AU*	CA	CN*	EP	GB*	IL	JP*	KR*	US*	IB
Applications published since	Jan 1, 2006	Jan 1, 2008			Jan 1, 2008					Jan 1, 1978
Published applications that are filed on and after	█	█	Feb 10, 2010	Jan 1, 1990	█	Jan 1, 2010	Dec 1, 1990	Jan 1, 1999	Jan 1, 2003	█
Specifications and Incoming Documents (e.g. claims, amendment)	Yes	Yes	Yes	Yes	Yes	Yes	Yes	Yes	Yes	Yes
Outgoing Documents (e.g. examination document)	Yes	Yes	Yes**	Yes	Yes	Yes**	Yes**	Yes**	Yes	Yes**

\*: Citation provided, \*\*: Including translation

# Possible Scene for Use of WIPO CASE

## ■ Routes of applications

Domestic

PCT route

Paris Convention route

Foreign applications



- They are filed or entered to individual countries nearly at the same timing.
- When they are filed from providing offices like JP, KR or US, their original examination results are available on WIPO CASE if examinations have started.
- Examiners can basically search for patent family by their own national application numbers.

# Possible Scene for Use of WIPO CASE

## ■ Example of examination procedure

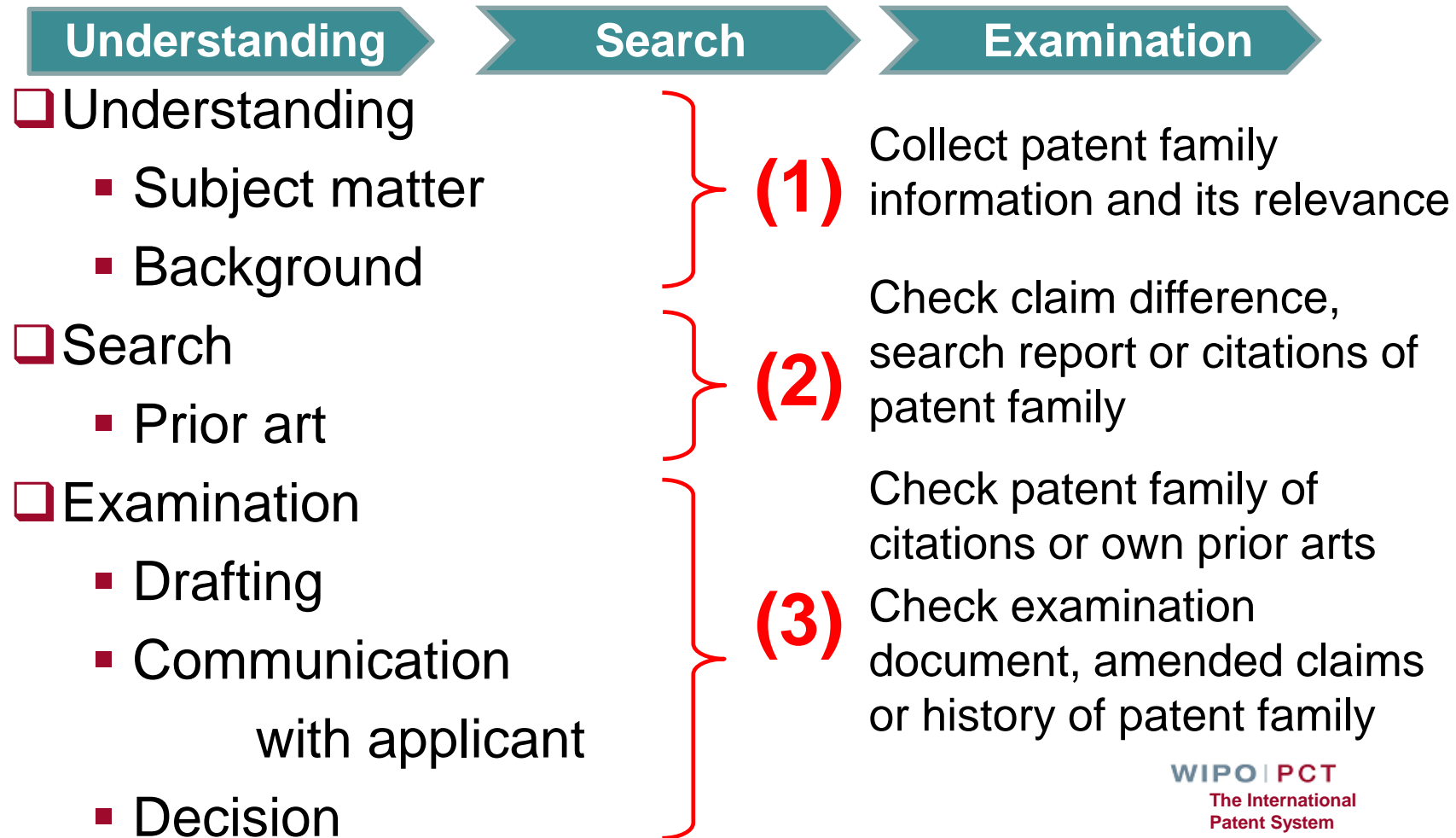

# Functions of WIPO CASE

## ■ WIPO CASE Web Portal

### □ Usability of user interface

- Time line
- Comparison of documents
- Linkage to PATENTSCOPE
- Translation
- Family citations

### □ Configurable preference

### □ Discussion forum

### □ Improved notification service



# WIPO CASE – Time Line

Home IP Services WIPO CASE Search

Preferences Users Notifications Notifications Data Coverage Statistics User Guide About

## WIPO CASE<sup>®</sup>

Application Number \*  [Extended](#) [Simple](#) e.g.: ( IL224004, GB1108683.2 ) [Compare](#) [Maximize](#)

GB1108683.2 ✕

[Time Line](#) [Tabular View](#) [Family Citations](#) [Discussion](#)

[View Application](#) [View Tree](#) [Subscribe](#) [Family Subscribe](#) [Update Indicators](#)

Year	Month	Event
2008	Oct	US12/258,610
2009	Oct	PCT/GB2009/002545
2009	Oct	SG2011028958
2009	Oct	CN200980147753.2
2011	Apr	CA2741617
2011	Apr	GB1108683.2

# WIPO CASE – View/Download Documents

Application Number \* GB1108683.2 Extended Simple e.g.: ( GB1108683.2, GB0814645.8 ) Compare Maximize

GB1108683.2

Document List

Document Name	Date	Pages/Size		Download	PDF	View	+
Specifications	2013-03-13	18p / 0.69 MB	<input type="checkbox"/>	↓	PDF	👁	+
Examination report	2012-10-01	1p / 0.05 MB	<input type="checkbox"/>	↓	PDF	👁	+
Examination report	2012-05-17	2p / 0.08 MB	<input type="checkbox"/>	↓	PDF	👁	+
Specifications	2011-10-12	2p / 0.04 MB	<input type="checkbox"/>	↓	PDF	👁	+
Claims Searched or Examined	2011-05-24	2p / 0.04 MB	<input type="checkbox"/>	↓	PDF	👁	+
Claims Searched or Examined	2011-05-24	3p / 0.07 MB	<input type="checkbox"/>	↓	PDF	👁	+
Specifications	2011-05-24	9p / 0.41 MB	<input type="checkbox"/>	↓	PDF	👁	+

View 1 - 7 of 7

Bibliographic Data  
Citation Data

Document: Examination report (2012-05-17)

**INTELLECTUAL PROPERTY OFFICE**

Your ref : 11538.30-00164  
 Application No: GB1108683.2  
 Applicant : Schlumberger Holdings Limited  
 Latest date for reply: 17 July 2012

Examiner : Alan Jones  
 Tel : 01633 813551  
 Date of report : 17 May 2012  
 Page 1/2

**Patents Act 1977  
 Examination Report under Section 18(3)**

**Basis of the examination**

1. In the examination of your application I have taken account of the pages 10 & 11 you filed with your agent's letter of 24 May 2011 to amend the application as it was printed by WIPO during the international phase. I confirm that I have taken into account the International Preliminary Report on Patentability dated 3 May 2011.

**Novelty**

2. The invention as defined in claims 1-3 & 7-10 is not new because it has already been disclosed in the following documents:

US4463220 A (GONZALES) See e.g. fig 2, interior cavity PI in fluid communication with drill string 15, gauge/stabiliser pads 11a, orifice 19 & col. 3 lines 62-65;  
 US5099934 A (BARR) See e.g. fig 1, interior cavity 13, gauge/stabilisation pads 18, 19, orifice 20 & col. 5 lines 29-37.

3. The above documents are relevant to the noted claims with reference to the features and passages highlighted against the identity of each document. Further discussion in relation to US4463220 A is also available by referring to Section V of the International Preliminary Report on Patentability dated 3 May 2011.

# WIPO CASE – Comparison of Documents

Application Number  Extended Simple e.g.: ( GB1108683.2, GB0814645.8 ) Compare Maximize

GB1108683.2 ✕

Document List

Document Name	Date	Pages/Size	
Specifications	2013-03-13	18p / 0.69 MB	<input type="checkbox"/>
Examination report	2012-10-01	1p / 0.05 MB	<input type="checkbox"/>
Examination report	2012-05-17	2p / 0.08 MB	<input type="checkbox"/>
Specifications	2011-10-12	2p / 0.04 MB	<input type="checkbox"/>
Claims Searched or Examined	2011-05-24	2p / 0.04 MB	<input type="checkbox"/>
Claims Searched or Examined	2011-05-24	3p / 0.07 MB	<input type="checkbox"/>
Specifications	2011-05-24	9p / 0.41 MB	<input type="checkbox"/>

Document: Examination report (2012-05-17)

INTELLECTUAL PROPERTY OFFICE

Your ref : 11538.30-00164      Examiner : Alan Jones  
Application No: GB1108683.2      Tel : 01633 813551  
Applicant : Schlumberger Holdings Limited      Date of report : 17 May 2012  
Latest date for reply:       Page 1/2

**Patents Act 1977**  
**Examination Report under Section 18(3)**

**Basis of the examination**

1. In the examination of your application I have taken account of the pages 10 & 11 you filed with your agent's letter of 24 May 2011 to amend the application as it was printed by WIPO during the international phase. I confirm that I have taken into account the International Preliminary Report on Patentability dated 3 May 2011.

**Novelty**

2. The invention as defined in claims 1-3 & 7-10 is not new because it has already been disclosed in the following documents:

US4463220 A (GONZALES)      See e.g. fig 2, interior cavity PI in fluid communication with drill string 15, gauge/stabiliser pads 11a, orifice 19 & col. 3 lines 62-65;  
US5099934 A (BARR)      See e.g. fig 1, interior cavity 13, gauge/stabilisation pads 18, 19, orifice 20 & col. 5 lines 29-37.

3. The above documents are relevant to the noted claims with reference to the features and passages highlighted against the identity of each document. Further discussion in relation to US4463220 A is also available by referring to Section V of the International Preliminary Report on Patentability dated 3 May 2011.

4. 11538.30-00164 - Examination Report under Section 18(3)

View 1 - 7 of 7

[Bibliographic Data](#)

[Citation Data](#)

# WIPO CASE – Comparison of Documents

## Document Comparison View

GB1108683.2\_Examination report\_2012-10-01



Your ref : 92-1194 GB PCT  
Application No: GB1108683.2  
Applicant : Schlumberger Holdings Limited  
Latest date for reply: 3 December 2012  
Page 1/1

Examiner : Alan Jones  
Tel : 01633 813551  
Date of report : 1 October 2012

### Patents Act 1977 Examination Report under Section 18(3)

#### Basis of the examination

1. My examination has taken account of the amendments filed with your agent's letter of 17 July 2012.

#### Support, clarity and consistency

2. The definition that the at least one orifice be positioned "at an angle approximately 90° relative to the plurality of cutters" is not clear. This is especially true as it is asserted in the second paragraph of page 2 of your agent's letter that "any suitable angle can be adopted". It is unclear what the scope of the claim is. What breadth does the term "approximately" cover? For, example does it cover 80°, 75°, 65°, any angle? If one but not another, then what integers does it cover intermediate these values? Of course, the principles of purposive construction as applied in *Catnic Components Ltd* and another v *Hill and Smith Ltd* [1982] RPC 183 and *PLG Research v Ardon* [1995] RPC 287 could be applied if the intended scope of the claims were determinable, but this is not considered the case.

3. While it is noted that a statement of invention has been added, the remainder of the description also requires revision so that it supports the definition of the invention outlined in the claims. For example, in the fourth paragraph of page 6 it is stipulated that "[i]n some embodiments, drill bit 105 contains a single orifice 212". This contradicts the claims that now require a plurality of orifices. This is one of many such inconsistencies. A further inconsistency that equally casts doubt on the invention is the statement under "Combination Anti-Whirl and Self Stabilization Bits" on page 9 that net imbalanced side forces can be produced, and reference to "[i]n such an embodiment", which imply that this is not essential but merely a possibility. Firm statements should be made to support inclusion of features that are deemed requirements by the claims.

4. There is a lack of clarity in the use of the term "imbalanced side force". It is not clear if this imbalance applies only to the object orifice and gage pad or whether it imbalances the whole drill bit. It also appears to contradict the assertion that it provides a net stabilising effect, unless it is counteracting another known force that has not been defined as part of the invention.

GB1108683.2\_Examination report\_2012-05-17



Your ref : 11538.30-00164  
Application No: GB1108683.2  
Applicant : Schlumberger Holdings Limited  
Latest date for reply: 17 July 2012  
Page 1/2

Examiner : Alan Jones  
Tel : 01633 813551  
Date of report : 17 May 2012

### Patents Act 1977 Examination Report under Section 18(3)

#### Basis of the examination

1. In the examination of your application I have taken account of the pages 10 & 11 you filed with your agent's letter of 24 May 2011 to amend the application as it was printed by WIPO during the international phase. I confirm that I have taken into account the International Preliminary Report on Patentability dated 3 May 2011.

#### Novelty

2. The invention as defined in claims 1-3 & 7-10 is not new because it has already been disclosed in the following documents:

US4463220 A (GONZALES) See e.g. fig 2, interior cavity PI in fluid communication with drill string 15, gauge/stabiliser pads 11a, orifice 19 & col. 3 lines 62-65;  
US5099934 A (BARR) See e.g. fig 1, interior cavity 13, gauge/stabilisation pads 18, 19, orifice 20 & col. 5 lines 29-37.

3. The above documents are relevant to the noted claims with reference to the features and passages highlighted against the identity of each document. Further discussion in relation to US4463220 A is also available by referring to Section V of the International Preliminary Report on Patentability dated 3 May 2011.

4. US5099934 A was discovered during a comparison with your equivalent US application, published as US2010/101867 A1.

#### Inventive step

5. The invention as defined in claims 4-6 is obvious in view of what has already been disclosed in the above documents. The definition of certain number of stabilising pads/orifices or certain angular spacing would be obvious in terms of normal design considerations. The definition of a valve would also be obvious to the skilled person in terms of being able to selectively actuate the stabilising fluid flow dependent on the particular downhole operation in hand.

# WIPO CASE – Bibliographic Data

Application Number  Extended Simple e.g.: ( GB1108683.2, GB0814645.8 ) Compare Maximize

GB1108683.2 ✕

Document List

Bibliographic Data

(21) Application No:	GB1108683.2	(22) Filing Date:	2009-10-26
(40) Publications:	GB2479475.B 2013-03-13, GB2479475.A 2011-10-12		
(26) Pub Language:		(25) Filing Language:	
(71) Applicant(s):	Schlumberger Holdings Limited;	(72) Inventor(s):	
(74) Agent(s):			
(51) IPC:	E21B 17/10 (2006.01), E21B 10/60 (2006.01)		
(31) Priority Details:	US 12/258,610		
(54) Title:	(EN) Self-stabilized and anti-whirl drill bits and bottom-hole assemblies and systems for using the same		
(57) Abstract:			
(85) National Entry:	2011-05-24		
(87) PCT Pub No:	WO2010/049674	(86) PCT App No:	<a href="#">PCT/GB2009/002545</a> <span>PATENTSCOPE</span>
(87) PCT Pub Date:	2010-05-06	(86) PCT Filing Date:	2009-10-26

Citation Data

  
**Linkage to PATENTSCOPE**



# WIPO CASE – Family Citations

GB1108683.2 ✕

Time Line | Tabular View | Family Citations | Discussion

Citation	Category	Claim-Ref	Status	Application
<a href="#">PATENTSCOPE</a> <a href="#">US4068731</a> A				US12/258,610
<a href="#">PATENTSCOPE</a> <a href="#">US6244361</a> B1				US12/258,610
<a href="#">PATENTSCOPE</a> <a href="#">US5520255</a> B1				US12/258,610
<a href="#">PATENTSCOPE</a> <a href="#">US200201199</a> A				US12/258,610
<a href="#">PATENTSCOPE</a> <a href="#">US4463210</a> A <b>2</b>				US12/258,610
<a href="#">PATENTSCOPE</a> <a href="#">US3455412</a> A				US12/258,610
<a href="#">PATENTSCOPE</a> <a href="#">US5553678</a> B1				US12/258,610
<a href="#">PATENTSCOPE</a> <a href="#">US20010052428</a> A1				US12/258,610
<a href="#">PATENTSCOPE</a> <a href="#">US5673763</a> B1				US12/258,610
<a href="#">PATENTSCOPE</a> <a href="#">US5582259</a> B1				US12/258,610
<a href="#">PATENTSCOPE</a> <a href="#">US5553679</a> B1				US12/258,610
<a href="#">PATENTSCOPE</a> <a href="#">US6092610</a> B1				US12/258,610
<a href="#">PATENTSCOPE</a> <a href="#">US6364034</a> B1				US12/258,610
<a href="#">PATENTSCOPE</a> <a href="#">US5706905</a> B1				US12/258,610
<a href="#">PATENTSCOPE</a> <a href="#">US5685379</a> B1				US12/258,610
<a href="#">PATENTSCOPE</a> <a href="#">US5971085</a> B1				US12/258,610
<a href="#">PATENTSCOPE</a> <a href="#">US7287604</a> B1				US12/258,610
<a href="#">PATENTSCOPE</a> <a href="#">US6386302</a> B1				US12/258,610
<a href="#">PATENTSCOPE</a> <a href="#">US5111892</a> B1				US12/258,610

Timeline: 2007 (Jan, Apr, Jul, Oct) | 2008 (Jan, Apr, Jul, Oct) | 2009 (Jan, Apr, Jul, Oct) | 2010 (Jan, Apr, Jul, Oct) | 2011 (Jan, Apr, Jul, Oct) | 2012 (Jan, Apr)



Timeline Markers: US12/258,610 (Oct 2008), PCT/GB2009/002545 (Oct 2009), GB1108683.2 (Apr 2011)

# WIPO CASE - Translation

Application Number \* IL224004 Extended Simple e.g.: ( IL224004, IL214023 ) Compare Maximize

IL224004 ✕

▼ Document List

Document Name	Date ↕	Pages/Size	<input type="checkbox"/> ↓ PDF
Examination report (TRANSLATED)	2013-11-17	5p / 0.05 MB	<input type="checkbox"/> ↓ PDF ○ +
Examination report (ORIGINAL)	2013-11-17	8p / 0.21 MB	<input type="checkbox"/> ↓ PDF ○ + 
Claims	2012-12-30	3p / 0.15 MB	<input type="checkbox"/> ↓ PDF ○ + 
Description	2012-12-30	42p / 0.4 MB	<input type="checkbox"/> ↓ PDF ○ + 
Drawings	2012-12-30	5p / 0.3 MB	<input type="checkbox"/> ↓ PDF ○ +

🔗 View 1 - 5 of 5

▶ Bibliographic Data

▶ Citation Data





# WIPO CASE - Notification

Application Number \* GB1108683.2 Extended Simple e.g.: ( GB1108683.2, GB0814645.8 ) Compare Maximize

GB1108683.2

Document List

Document Name

Specifications

Examination report

Examination report

Specifications

Claims Searched or Examined

Claims Searched or Examined

Specifications

⌘

Bibliographic Data

Citation Data

**Notification**

Are you sure you want to Subscribe !

Yes No

View 1 - 7 of 7

Time Line Tabular View Family Citations Discussion

View Application View Tree Subscribe Family Subscribe Update Indicators

Timeline showing patent events from 2008 to 2011. Key events include:

- US12/258,610 (Oct 2008)
- SG2011028958 (Oct 2010)
- PCT/GB2009/002545 (Oct 2009)
- CN200980147753.2 (Oct 2009)
- GB1108683.2 (Jan 2011)

2008 2009 2010 2011

# WIPO CASE – Link to WIPO CASE

Application Number \* CN201010134080.1 Extended Simple e.g.: (

CN201010134080.1 x

Document List

Bibliographic Data

Citation Data

Citation

PATENTSCOPE US5909598 A (DOCDB)

PATENTSCOPE CN101206382 (DOCDB)

PATENTSCOPE CN1233772 A (DOCDB)

PATENTSCOPE

PATENTSCOPE

Click citation numbers for another search on WIPO CASE

Application Number \* CN201010134080.1 Extended Simple e.g.: ( CN201010134080.1, CN201010531379.0 )

CN201010134080.1 x CN101206382 x

Time Line Tabular View Family Citations Discussion

View Application View Tree S

US11/999,063

JP2006340912

CN200710161034.0

Jan 2006 Apr Jul Oct Jan 2007 Apr Jul Oct Jan 2008

The screenshot displays the WIPO PATENTSCOPE interface. At the top, the search criteria are set to 'Application Number' with the value 'CN201010134080.1'. Below this, the 'Citation Data' section is expanded, showing a list of citations. A red arrow points to the citation 'CN101206382 (DOCDB)'. Below the citation list, a 'Time Line' view is shown for the selected citation. The timeline is a horizontal axis with markers for Jan 2006, Apr, Jul, Oct, Jan 2007, Apr, Jul, Oct, and Jan 2008. A red dashed box highlights the timeline view, which includes a 'View Application' button and a 'View Tree' button. The timeline shows a citation 'JP2006340912' in late 2006 and 'US11/999,063' in early 2007. A warning icon is present next to 'CN200710161034.0' in late 2007.