Session 2

Accessing PCT Products and Other

Office's Work Products

(AIPN)

Case study

Japan Patent Office
September 13th, 2016

Access to the AIPN

■ URL

- <https://aipn.j-platpat.inpit.go.jp/AI2/cgi-bin/AIPNSEARCH>

■ ID

- wipojpo1

■ Password

- wipojpo1

*This ID and Password are effective only in this workshop.

Exercise 1: Retrieve following application

- application number JP1999-105956

- Patent Family of MXPA01010478A, etc.
- JP1999-105956 contains the useful information for examination of Mexican patent application MXPA01010478A, etc.

Exercise 1: Retrieve following application - application number JP1999-105956



National Center for Industrial Property Information and Training

Advanced Industrial Property Network

News Help

This service is available to authorized industrial property offices only.
Any secondary use such as offering of translation service to the third party is prohibited.

Search from JAPANESE Application/Priority/Publication/Patent Number

Type

Document Number

Display Type File Wrapper Information Patent Family

Note: Please select "Patent Family" when you search by PCT international publication number as corresponding file wrapper information is not directly accessible.

[Click here for Stored Data Information.](#)

Search from OTHER Application/Priority Number

Application Number

Priority Number

Select up to 3 technical dictionaries in order of priority.

Dictionary1

Dictionary2

Dictionary3

Exercise 2: Display and confirm examiner's opinion

Patent application number 1999-105956

File Wrapper Document List - Click document title to display contents.
The dates in the list are shown in the format of "dd.mm.yyyy"

Application data and Transaction history

- 13.04.1999: Request for a Patent
- 13.04.1999: Description
- 13.04.1999: Drawings
- 13.04.1999: Abstract
- 17.04.2002: Request for Examination
- 17.04.2002: --- Certified or Appended Information
- 17.04.2002: Written Amendment
- 17.04.2002: --- Certified or Appended Information
- 18.11.2003: Notification of Reasons for Refusal
- 14.01.2004: Written Argument
- 14.01.2004: --- Certified or Appended Information
- 14.01.2004: Written Amendment
- 14.01.2004: --- Certified or Appended Information
- 01.06.2004: Decision of Refusal
- 14.10.2004: Written Argument (Formality)
- 18.04.2005: Notification of Reasons for Refusal
- 18.04.2005: Appointment of Power of Attorney

Notification of Reasons for Refusal

Application number: Heisei 11(1999) Request for a Patent
Date of Drafting: Heisei 15(2003) November 11
Patent examiner: KURIYAMA, Takuya 9628 3K00
Representative/Applicant: SHIRAHAMA, Yoshiharu
Applied Provisions: Article 29(2)

Clause of the patent law applied by examiners

This application should be refused for the reason mentioned below. If the applicant has an argument against the reason, such argument should be submitted within 60 days from the date on which this notification was dispatched.

Reason

The claimed invention(s) in the each claim listed below of this patent application should not be granted a patent under the provision of Patent Law Article 29 (2) for the reason that the claimed invention(s) could have easily been made by persons who have common knowledge in the technical field to which the claimed invention(s) pertains, on the basis of the invention(s) described in the distributed publication(s) listed below in Japan or other foreign countries prior to the filing of the patent application.

Note (See the list of cited documents etc., below.)

[- Claim: 1 - Cited Documents: 1 and 2 Remarks cited document 1] It consists of synthetic resin continuous glass fiber of many hot welding nature which, and is extended to one way, [of hot welding nature] [a plastic sheet and] [the] The disposable dirt wiping tools joined to the sheet with the welding line of two or more sections which continuous glass fiber extended in the direction which intersects one way, and is arranged intermittently to one way are described, and the sheath-core type conjugate fiber whose melting temperature of a sheath is lower than that of a core 30 degrees C or more is described in cited document 2. It is admitted that it is easy for a person skilled in the art to make the invention in this application from the thing of above-mentioned document 1 and 2.

- Claim: 2 - Cited Documents: 1 and 2

Remarks

The sheath-core type conjugate fiber whose melting temperature of a sheath is lower than that of a core 70 degrees C or more is described in cited document 2. It is admitted that it is easy for a person skilled in the art to make the invention in this application from cited document 1 and the thing of 2.

Notification of Reasons for Refusal

Reason why examiners think it unpatentable

Exercise 3: Translate the text to your familiar language

Disclaimer:

Translation from English to other languages is performed by GoogleTranslate function. Since this function is based on machine translation, the translation result might be inaccurate. The JPO and the INPIT are not responsible for any damage that may be caused by the use of this function or the translation result.

Penolakan:

Terjemahan bahasa Inggris ini diproduksi oleh terjemahan mesin dan mungkin mengandung kesalahan. JPO, yang INPIT, dan orang-orang yang merancang dokumen ini dalam bahasa aslinya tidak bertanggung jawab atas hasil terjemahan.

Catatan:

1. kata diterjemahkan diganti dengan tanda bintang (****).
2. Teks dalam angka-angka tidak diterjemahkan dan ditampilkan seperti itu.

Diterjemahkan: 11:00:42 JST 2016/08/31
Kamus: terakhir diperbarui 2016/07/24 / Prioritas:

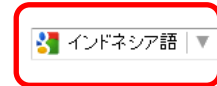

You can translate the text to your familiar language

Aplikasi paten nomor 1999-105956

Berkas Wrapper Dokumen Daftar - Klik pada judul untuk menampilkan isi dokumen tersebut tanggal dalam daftar yang ditampilkan dalam format "dd.mm.yyyy"

■ [data aplikasi dan sejarah transaksi](#)

1. [1999/04/13: Permintaan Paten](#)
2. [1999/04/13: Keterangan](#)
3. [1999/04/13: Gambar](#)
4. [1999/04/13: Abstrak](#)
5. [2002/04/17: Permintaan Pemeriksaan - - - - - : Informasi Bersertifikat atau Ditambahkan](#)
6. [2002/04/17: Ditulis Perubahan - - - - - : Informasi Bersertifikat atau Ditambahkan](#)
7. 2003/11/18: Pemberitahuan Alasan Penolakan
8. [2004/01/14: Ditulis Argumen - - - - - : Informasi Bersertifikat atau Ditambahkan](#)
9. [2004/01/14: Ditulis Perubahan - - - - - : Informasi Bersertifikat atau Ditambahkan](#)
10. [2004/06/01: Keputusan Penolakan](#)
11. [2004/10/14: Ditulis Perubahan \(Formalitas\)](#)
12. [2005/04/18: Pemberitahuan Pengunduran Diri Surat Kuasa](#)

Pemberitahuan Alasan Penolakan

Nomor aplikasi: Heisei 11 (1999) Permintaan Paten No. 105956
Tanggal Drafting: Heisei 15 (2003) November 11
pemeriksa Paten: Kuriyama, Takuya 9628 3K00
Perwakilan / Pemohon: Shirahama, Yoshiharu
Ketentuan Terapan: Pasal 29 (2)

ini aplikasi harus ditolak karena alasan yang disebutkan di bawah. Jika pemohon memiliki argumen terhadap alasan, dalil tersebut harus diserahkan dalam waktu 60 hari dari tanggal pemberitahuan ini dikirim.

Alasan

Penemuan mengklaim (s) di setiap klaim yang tercantum di bawah aplikasi paten ini tidak boleh diberikan paten berdasarkan ketentuan UU Paten Pasal 29 (2) dengan alasan bahwa penemuan diklaim (s) bisa dengan mudah dilakukan oleh orang yang memiliki pengetahuan umum di bidang teknis yang penemuan diklaim (s) berkaitan, atas dasar penemuan (s) digambarkan dalam publikasi didistribusikan (s) yang tercantum di bawah di Jepang atau negara asing lainnya sebelum pengajuan paten aplikasi.

Catatan (Lihat daftar dokumen yang dikutip dll, di bawah ini.)

[- Klaim: 1 - Dikutip Dokumen: 1 dan 2 Keterangan dikutip dokumen 1] Ini terdiri dari resin sintesis fiber glass terus menerus dari banyak alam pengelasan panas yang, dan diperpanjang untuk satu arah, [alam pengelasan hot] [selembar plastik dan] [yang] kotoran pakai menyeka alat bergabung ke lembar dengan garis las dari dua atau lebih bagian yang fiber glass terus menerus diperpanjang ke arah yang memotong salah satu cara, dan diatur sebentar-sebentar ke salah satu cara yang dijelaskan, dan selubung-core Jenis

Exercise 4: Display and confirm cited documents

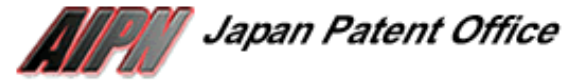

National Center for Industrial Property Information and Training

Advanced Industrial Property Network

News Help

This service is available to authorized industrial property offices only.
Any secondary use such as offering of translation service to the third party is prohibited.

Search from JAPANESE Application/Priority/Publication/Patent Number

Type

Document Number

Display Type File Wrapper Information Patent Family

Note: Please select "Patent Family" when you search by PCT international publication number as corresponding file wrapper information is not directly accessible.

[Click here for Stored Data Information.](#)

Search from OTHER Application/Priority Number

Application Number

Priority Number

Select up to 3 technical dictionaries in order of priority.

Dictionary1

Dictionary2

Dictionary3

Exercise 4: Display and confirm cited documents

AIPN Japan Patent Office
Advanced Industrial Property Network

National Center for Industrial Property Information and Training

HELP **STORED DATA** **SEARCH**

Searched Number : [1999-105956](#) **Legal status, Cited documents**

Patent Family

No.	Kind	Publication No.	Publ. Date	Application No.	Appl. Date	Related Information.
1	A	JP 2000-296085	24.10.2000	JP 1999-0105956	13.04.1999	Legal status, Cited documents
2	B1	HU 229468	30.12.2013	HU 200742	12.04.2000	
3	T3	ES 2358976	17.05.2011	ES 915498	12.04.2000	
4	T	AT 496569	15.02.2011	AT 915498	12.04.2000	

Legal Status, Cited Documents Application Number. JP 1999-0105956 **File Wrapper Information**

Legal Status Click "File Wrapper Information" for the latest status.

[Publication number]	2000-296085
[Date of request for examination]	17.04.2002
[Date of sending the examiner's decision of rejection]	01.06.2004
[Kind of final disposal of application other than the examiner's]	
[Date of final disposal for application]	
[Patent number]	
[Date of registration]	
[Number of appeal against examiner's decision of rejection]	2004-013501
[Date of requesting appeal against examiner's decision of rejection]	30.06.2004
[Date of extinction of right]	
[Trial or opposition number]	
[Date of demand for trial or opposition]	
[Kind of final disposal of trial or opposition]	
[Date of final disposal of trial or opposition]	
[Renewal date]	13.07.2007

Cited Documents

No.	Kind	Document No.	Patent Family
1	A	JP 09-135798	Patent Family
2	U	JP 06-24665	Patent Family
3	A	JP 05-192284	Patent Family
4	A	JP 10-272081	Patent Family

Patent family

Legal status

Cited documents

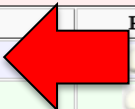

Exercise 4: Display and confirm cited documents

Full document

English Translation of Full Document

Japanese Full Document

ADVANCED INDUSTRIAL PROPERTY NETWORK

PATENT ABSTRACTS OF JAPAN

(11)Publication number : 09-135798

(43)Date of publication of application : 27.05.1997

(51)Int.Cl.

A47L 13/17

(21)Application number : 07-300249

(71)Applicant : UNI CHARM CORP

(22)Date of filing : 17.11.1995

(72)Inventor : KENMOCHI YASUHIKO
ISHIKAWA HIROKI

(54) DISPOSABLE WIRING TOOL

(57)Abstract:

PROBLEM TO BE SOLVED: To prevent fibers of a disposable wiping tool from coming off.

SOLUTION: This disposable wiping tool 1 is comprises a sheet part 10 and a lot of thermal melt-stuck long fibers 25 extended in one direction while being bonded onto one side 10A or 10B of the sheet at least, and a lot of long fibers 25 are bonded onto the sheet part 10 by plural melt-sticking wires 9 extended across the fibers and intermittently arranged in the lengthwise direction of long fibers.

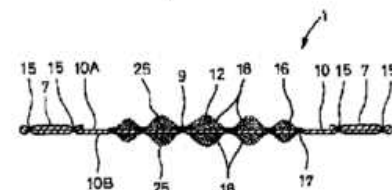
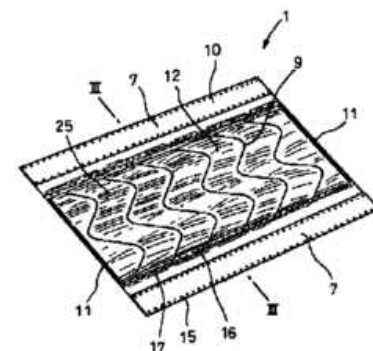

English translation
by human

Exercise 4: Display and confirm cited documents

contents

P,09-135798,A(1997)]

Japanese (PDF) File Wrapper Information

[FULL CONTENTS](#) [CLAIM + DETAILED DESCRIPTION](#) [DESCRIPTION OF DRAWINGS](#) [DRAWINGS](#)

Disclaimer:

Translation from English to other languages is performed by GoogleTranslate function. Since this function based on machine translation, the translation result might be inaccurate. The JPO and the INPIT are not responsible for any damage that may be caused by the use of this function or the translation result.

English translation is produced by machine translation and may contain errors. The JPO, the INPIT, and those who drafted this document in the original language are not responsible for the result of the translation.

Untranslatable words are replaced with asterisks (****).
Texts in the figures are not translated and shown as it is.

Translated: 11:11:16 JST 08/31/2016
Dictionary: Last updated 07/24/2016 / Priority:

言語を選択

You can translate the text to your familiar language

CLAIM + DETAILED DESCRIPTION

[Claim(s)]

[Claim 1] They are the disposable wiping tools consisting of many hot welding continuous glass fiber which is joined to a hot welding sheet and the sheet, and is extended unidirectionally. The aforementioned wiping tools having joined to the aforementioned sheet with a plurality of welding lines which the aforementioned continuous glass fiber extended in the direction which intersects this, and were intermittently arranged by longitudinal direction of the continuous glass fiber.

[Claim 2] The wiping tools according to claim 1 which are a plurality of coil gland which the aforementioned welding line intersects the aforementioned continuous glass fiber aslant substantially, and is mutually parallel.

[Claim 3] The wiping tools according to claim 1 whose aforementioned welding lines are a plurality of parallel straight lines which cross the aforementioned continuous glass fiber and aslant.

[Claim 4] The wiping tools according to claim 3 which the aforementioned welding lines are a plurality of straight lines which cross the aforementioned continuous glass fiber and aslant, and these straight lines cross mutually, and are presenting a lattice pattern as a whole.

[Claim 5] The wiping tools according to claim 1 whose aforementioned hot welding sheets are either a plastic film and a nonwoven fabric.

[Claim 6] The wiping tools according to claim 1 with which said many continuous glass fiber opens a tow of a hot welding continuous filament.

[Detailed Description of the Invention]

[0001]

[Field of the Invention] This invention relates to the wiping tools of throwing away used in order to clean a floor etc.

Report Mistranslation

Japanese (whole document in PDF)

Drawing selection Representative drawing

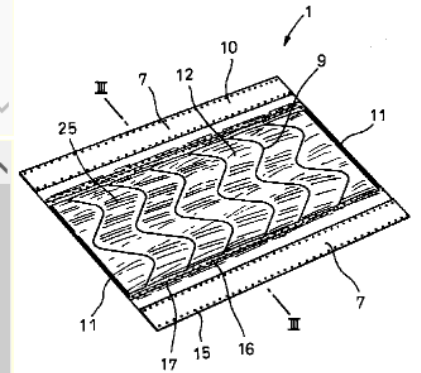

Thank You !