



WORLD
INTELLECTUAL
PROPERTY
ORGANIZATION

WIPO MAGAZINE

GENEVA - DECEMBER 2006 - No.6

2

2006 WIPO ASSEMBLIES

8



FIFTY YEARS OF THE VIDEO RECORDER

12



SOUTH AFRICA INNOVATION FOR DEVELOPMENT

Third Global Congress on Combating Counterfeiting and Piracy

Shared Challenges - Common Goals



Date: January 30 and 31, 2007

Venue: International Conference Center, Geneva, Switzerland

Information: For details and registration see www.ccapcongress.net

With the worldwide trade in counterfeit products posing multiple threats to health and safety, economic development and good governance, the Global Congress has become a key international forum for shaping strategies to tackle the challenges.

The Third Global Congress, hosted by WIPO in Geneva, will build on the process that began in Brussels in 2004, bringing together top government and private sector players to pool their experience, enhance international coordination, and seek more effective solutions in pursuit of the common goals of combating counterfeiting and piracy.

Early registration is recommended, as attendance will be limited in order to allow for maximum interaction among participants.

The Congress is co-convened by WIPO, the World Customs Organization (WCO) and Interpol, in cooperation with the International Trademark Association (INTA), the International Chamber of Commerce (ICC), the International Security Management Association (ISMA) and the Global Business Leaders Alliance Against Counterfeiting (GBLAAC).

WIPO MAGAZINE ISSUE 2006/6

Editorial team

John Tarpey
Elizabeth March
Sylvie Castonguay

WIPO staff contributors

Tamara Nanayakkara, Marcus Hopperger,
Martin Senfleben: **Trademark Coexistence**

Acknowledgements

– *Artesanías de Colombia*
– Raquel Pérez Alberdi; María Valeria Rapetti Tizze

Graphic design

Sheyda Navab

©World Intellectual Property Organization

CONTENTS

- 2 RESULTS OF THE **2006 ASSEMBLIES** OF WIPO MEMBER STATES
- 6 ARTS AND CRAFTS OF **COLOMBIA**
- 8 50 YEARS OF THE VIDEO CASSETTE RECORDER
- 12 **COUNTRY FOCUS**
INNOVATION TO DRIVE DEVELOPMENT -
A **SOUTH AFRICAN** PERSPECTIVE
- 14 WHEN INNOVATION IS **CHILD'S PLAY**
- 16 **PCT PORTRAITS**
Nobel Prize for the Silence of the Genes
Metal Magician meets Medical Wizard
Pills from Poisons
- 18 **IP AND BUSINESS**
TRADEMARK COEXISTENCE
- 20 CYBERSQUATTER OR **INNOCENT FAN?**
- 21 TEACHING COPYRIGHT TO **TEENAGERS**
- 22 **NEWS ROUNDUP**
WIPO Report Shows Internationalization of Patent Trends
Superman Takes on DVD Pirates
Masters of Invention
900,000 Trademarks Registered under the Madrid System
- 24 **LETTERS** AND COMMENT
- 27 **WIPO AWARDS**
- 28 **CALENDAR** OF MEETINGS
- NEW **PRODUCTS**

RESULTS OF THE 2006 ASSEMBLIES OF WIPO MEMBER STATES

“As a global body encouraging creativity and innovation, as well as being a market-oriented provider of services for a demanding cross-section of users, WIPO’s constituency is wide. Our goal has been to ensure that the totality of that constituency is included in the drive to help identify, protect and use intellectual assets.”

Director General Kamil Idris in his opening address to the Assemblies.

The Assemblies of WIPO’s 183 Member States concluded on October 3, having achieved consensus on every item on the agenda.

At the closing session, Director General Kamil Idris thanked delegates for the wisdom they had brought to bear during the

discussions and for their good will in ensuring that all items handled by the General Assembly were concluded successfully. He looked forward to the continuation of this spirit of determination and commitment to enable the Organization to face the challenges ahead. The WIPO General Assembly was chaired by Ambassador Enrique Manalo, Permanent Representative of the Philippines to the United Nations and other international organizations in Geneva, who joined Dr. Idris in extolling the constructive approach which had prevailed throughout the Assemblies.

The principal decisions of the meetings that took place from September 25 to October 3 include the following:

Program and budget

The Assemblies adopted a new mechanism for the preparation and follow up of the program and budget which strengthens the role of Member States. Members welcomed the Secretariat’s progress report on the implementation of the Joint Inspection

Unit’s recommendations, including progress on the desk-to-desk review. They also welcomed a report on the Secretariat’s initiatives in the last year to strengthen budgetary control and managerial processes, including a comprehensive revision of human resources strategies, procurement procedures and internal oversight.

Development Agenda

The General Assembly renewed the mandate of the Provisional Committee on Proposals Related to a WIPO Development Agenda (PCDA) for a further year. Member States reviewed the two sessions of the PCDA in February and June 2006, and emphasized the need to continue discussions on the proposals submitted so far in the process. The General Assembly agreed that the PCDA would hold two 5-day sessions to allow for structured in-depth discussions on all 111 proposals made so far. The lists of proposals to be discussed in the first and second sessions were identified.

In order to streamline the process of examining all proposals in an inclusive manner, the PCDA will seek to narrow down the proposals to eliminate repetition or duplication; separate actionable proposals from declarations of general principles and objectives; and note those proposals which relate to existing activities in WIPO and those which do not. Ambassador Manalo will produce initial working documents in consultation with Member States.

The PCDA will report to the 2007 General Assembly, with recommendations for action on agreed proposals, and a framework for considering further proposals following the 2007 General Assembly. In the interim, and without prejudice to the provision of technical assistance, Member States agreed that the Permanent Committee on Intellectual Property and Development (PCIPD), which was established in 1999 to deal with matters relating to cooperation for development, will cease to exist.



Photo: WIPO/Mercedes Martinez Dozal

“The positive results of this meeting can be attributed to all the Member States’ unrelenting efforts to arrive at decisions by consensus on the major issues on our agenda.” **Ambassador Enrique Manalo, Chair of the General Assembly**

In line with the earlier sessions of the PCDA in 2006, WIPO will provide financing to facilitate the attendance at PCDA meetings of representatives from developing countries, least developed countries (LDCs) and countries in transition.

Rights of broadcasting organizations

The General Assembly agreed to convene a diplomatic conference from November 19 to December 7, 2007, with a view to concluding a treaty on the protection of broadcasting organizations, including cablecasting organizations.

The decision sets a roadmap for the last leg of negotiations, including two special sessions of the Standing Committee on Copyright and Related Rights (SCCR) in January and June to clarify the outstanding issues and to “aim to agree and finalize, on a signal-based approach, the objectives, specific scope and object of protection.” The discussions are confined to the protection of traditional broadcasting organizations and cablecasting following a decision by the May 2006 session of the SCCR to examine questions of webcasting and simulcasting on a separate track.

Law of Patents

Member States agreed on a way forward in respect of discussions held in the context of WIPO’s Standing Committee on the Law of Patents (SCP). They decided that proposals regarding the work program of the SCP, including proposals on different approaches, may be submitted by December 2006. Proposals will be circulated in consolidated form to all Member States. They agreed that the Chairman of the General Assembly would hold informal, inclusive consultations in the first half of 2007 to discuss the proposals and would recommend a work plan for the SCP to the General Assembly in September 2007. The General Assembly in September 2007 will consider the results of the consultations with a view to establishing a work plan for the SCP for 2008 and 2009.

The Secretariat also informed Member States that a series of informal information meetings would be held in Geneva from October 2006 to September 2007 on patent-related topics, including research exemption; technical standards; flexibilities in the patent system; national strategies for innovation; and transfer of technology. The first two colloquia will take place on October 11 and November 29, 2006, respectively.

Singapore Treaty on the Law of Trademarks

Member States expressed support for the Singapore Treaty on the Law of Trademarks, which was concluded in March 2006 and will enter into force when 10 countries or intergovernmental organizations ratify or accede to the Treaty. Member States also welcomed a resolution by the diplomatic conference to provide assistance to least developed and developing countries to facilitate implementation of the Treaty in those countries. Implementation of the Singapore Treaty will enable national and regional trademark administration authorities to benefit from simplified procedures, including electronic means of communication. This will reduce procedural transaction costs and provide additional incentives for business to invest and expand internationally.

Genetic Resources, Traditional Knowledge and Folklore

Member States expressed their commitment to accelerating the work of the Intergovernmental Committee on Intellectual Property and Genetic Resources, Traditional Knowledge and Folklore (IGC), and to generating tangible results. Member States also welcomed the implementation of the Voluntary Fund, established at the 2005 General Assembly, to finance the participation of representatives of accredited observers representing indigenous and local communities. The Voluntary Fund has attracted a number of pledges, which promise to make it operational in time for the December meeting of the IGC.



“This Organization has crafted programs of benefit to all nations; it is a world-class provider of intellectual property services and the main global intellectual property norm-setting body. It must seek to strengthen that position and to inspire for future generations a genuine, inclusive, well-grounded intellectual property culture.”

Director General Kamil Idris

Audiovisual performances

Member States noted the status of consultations on the protection of audiovisual performances and agreed to keep the issue on the agenda of the General Assembly in September 2007. The purpose of a new instrument would be to strengthen the position of performers in the audiovisual industry by providing a clearer legal basis for the international use of audiovisual works, both in traditional media and in digital networks. The General Assembly also noted the Director General's proposal to organize national and regional seminars in the coming year in order to explore the issues at stake and the various solutions found in existing national legislation and contractual practices.

Enforcement

Member States took note of the work of the Advisory Committee on Enforcement (ACE), particularly in the field of education, awareness building, and training, in all areas of IP enforcement.

PCT

Member States endorsed the appointment of the Nordic Patent Institute, comprising the patent offices of Denmark, Iceland and Norway, as an International Searching and Preliminary Examining Authority under the Patent Cooperation Treaty (PCT). The PCT Assembly also reviewed the status of the PCT reform

process, which is designed to ensure that the PCT is in line with the needs of the user community. Delegates noted the significant productivity gains in the past three years due to the increasing use of information technologies in PCT procedures.

Member States endorsed a proposal to establish a digital access service for priority documents. This is a voluntary arrangement designed to save applicants from having to produce proof of filing of the original application separately in each state where priority is claimed. A working group will be convened in early 2007 to help establish the procedures.

Madrid System

The Assembly of the Madrid Union for the international registration of trademarks examined provisions concerning the refusal procedure, as required under the Madrid Protocol ten years after its entry into force. Members concluded that this was functioning satisfactorily and required no substantive change. The Madrid Assembly also adopted an interpretative statement allowing for further reviews of the operation of the refusal procedure in the future.

The Madrid Assembly adopted a number of amendments to the Common Regulations under the Madrid Agreement and Protocol which govern the international trademark registration system. Most of the amendments will take effect as from April 1, 2007. Member States also adopted amendments relating to the continuation of the effects of

international registrations in a state that becomes independent from another Member State. These provisions establish a simple procedure allowing holders of international registrations to maintain their international registration in the newly independent country.

The Madrid Assembly also extended the mandate of the Working Group on the Legal Development of the Madrid System to continue discussion of a possible review of the “safeguard clause” in the Madrid Protocol and to ensure that the System will continue to meet the needs of the user community.



Photo: WIPO/Mercedes Martinez Dozal

Director General Kamil Idris met with government representatives of many Member States. Here Haiti's Minister of Culture and Communication, Mr. Daniel Elie, discusses WIPO support for Haiti to develop human resources training and IP office infrastructure.

Observers

In line with WIPO's commitment to transparency and inclusive debate, the Assemblies granted observer status to a number of international non-governmental organizations. These include the Arab Federation for the Protection of Intellectual Property Rights (AFPIPR); the European Commercial Patent Services Group (PatCom); and 3D – Trade – Human Rights – Equitable Economy (3D).

Organizations granted observer status are invited to attend the meetings of WIPO Assemblies and other meetings of direct interest to them. Nine additional national non-governmental organizations, considered to be in a position to offer constructive and substantive contributions to the deliberations of WIPO Assemblies, were granted observer status in conformity with a decision by WIPO Member States in October 2002. At present, 67 inter-governmental organizations (IGOs), 203 international NGOs and 40 national NGOs have observer status with WIPO.

Arbitration and mediation

The General Assembly reviewed WIPO's activities in relation to the protection of IP in the Internet Domain Name System. Currently an average of 4.5 new domain name cases are filed with the WIPO Arbitration and Mediation Center each day. Member States noted the status of recommendations made by the 2002 WIPO General Assembly in relation to the Second WIPO Internet Domain Name Process, which concerns the relationship between domain names and certain types of identifiers other than trademarks. The Internet Corporation for Assigned Names and Numbers (ICANN) is now considering recommenda-

tions for the protection of the names and acronyms of international intergovernmental organizations (IGOs).

Program Performance Report

The WIPO Assemblies approved the results-based Program Performance Report of the Organization for the 2004-2005 biennium. The WIPO Assemblies also took note of information on the implementation of major activities in the first half of 2006, including the Progress Report on the New Construction Project, informing Member States about progress made since the WIPO Assemblies in 2005.

ARTS AND CRAFTS OF COLOMBIA

Photos courtesy of Artesanías de Colombia



1

2

3

Close to one million people in Colombia earn a living directly or indirectly from the country's vibrant arts and crafts sector. A significant contributor to the national economy, the sector counts some 350,000 artisans, approximately 60 percent of whom are from rural and indigenous areas, and 65 percent of whom are women. The richness and diversity of the country's arts and crafts was on display at a unique exhibition at WIPO headquarters from September 25 to October 12, which was organized jointly by WIPO and the Colombian Government.

Photo: WIPO/Mercedes Martínez Dozal



A Wayúu design on a traditionally woven hammock.

The exhibits were drawn from the collection of *Artesanías de Colombia*, a government institution responsible for the promotion and development of the country's artisanal and craft sector. The Colombian government encourages artisans to use the intellectual property system as a means of protecting their creative works and obtaining just remuneration for their efforts, while also preserving the country's national patrimony for future generations.

Opening the exhibition, Ambassador Clemencia Forero Ucross, Permanent Representative of Colombia to the United Nations in Geneva, described Colombian crafts as the ultimate representation of the country's culture, idiosyncrasy and folklore. She stressed the importance for a country like Colombia of "working hand-in-hand with WIPO for the protection of our cultural expressions."

The exhibition featured jewelry, silverware, basketry, tapestry, ceramics, wood masks and finely woven objects, produced in different regions and by a cross section of indigenous groups. Space permits us here to touch on only three of these traditional art forms.

Heritage of the Zenú

4



5



6



7



The Vueltiao hat (4), one of the best known and popular symbols of Colombia, is the Colombian craft *par excellence*. The hats are the work of the Zenú ethnic group, who use traditional colors, designs and weaving techniques that date back over a thousand years. The Zenú use a complex traditional method to transform the natural caña flecha palm tree fiber (5-6) into black and white fibers (7) that they then weave into patterns representing the totemic elements of the Zenú culture. These carry traditional names, such as Heart of the Fan, Crocodile Flower, etc. The Zenú use their traditional techniques today to create a range of products for the home.

The Caña Flecha Hat, designed by Olga Piedrahita, shown here at the Identidad Colombia (Colombia Identity) fashion show.



Weaving of the Waleker

The women of the Wayúu ethnic group, from the Guajira Peninsula on the Colombia-Venezuela border, claim that they learned their weaving skills from *Waleker* – the spider. The secrets of their traditional weaving are part of the initiation rites of adolescent girls to womanhood. The intricate hand-stitched *kanás* (weaving designs) are an ancient Wayúu art form and represent the elements found in the matriarchal structure of their society, environment and daily life.

The Wayúu also use traditional techniques to make bags, sandals, rugs and beautiful pottery jars to transport water.

Pasto Glazing – the resin of the Mopa-mopa



The indigenous people of the Nariño Department of Colombia, developed a technique for extracting the resin of the *mopa-mopa* tree, which they cook and color with vegetable dyes to produce laminae. These they apply to the surface of wooden items, creating striking designs. The thousand-year old technique, known as Pasto Glazing, is unchanged today, and is now used to create contemporary designs on trays and plates (1-2), vases (8), boxes and other objects (10).

The technique requires a delicate touch as the colored fragments must be placed precisely on the wood surface to create the textures and tones of the designs.

The black and red pottery of La Chamba

Horse and Rider (3), a black pottery piece by Eduardo Sandoval, was made using the traditional techniques of the people of La Chamba which he learnt from his grandfather. La Chamba potters create black or red ceramic pieces, which they polish by friction with agate and river stones. Mr. Sandoval learnt the techniques as a lad, then went on to study fine arts, painting and sculpture. He has La Chamba clay delivered regularly to his Bogota studio and melds the techniques of his youth with that of his academic training to create unique works, which have won local recognition.

50 YEARS OF THE VIDEO CASSETTE RECORDER

Press Play

Invented in 1956, the technology which produced the video cassette recorder (VCR) is already at the end of its days. But in its 50 years life span the VCR revolutionized the movie industry, changed television-watching habits, triggered the first “format wars,” and raised new copyright questions, establishing jurisprudence on fair use.

When television first took off in the 1950s, the only means of preserving video footage was through kinescope, a process in which a special motion picture camera photographed a television monitor. Kinescope film took hours to develop and made for poor quality broadcasts. So most television networks just made live broadcasts direct from the studio. But in countries with several time zones, live broadcast was a problem. In the U.S., for example, the 6 p.m. news broadcast in New York, if aired direct, would

be on at 3 p.m. Pacific time in Los Angeles. The only solutions were to repeat the live broadcast three hours later for LA, or to develop the kinescope film of the first broadcast and rush to air it on time. There was a pressing need for new recording technology.

The big electronic companies of the day raced to develop the technology, working on recorders that used magnetic tape. The Ampex Corporation, however, working in secrecy, based its research on a rotating head design, which had been patented by an Italian inventor in 1938 for use in audio recordings. After several failed attempts, and having abandoned the project altogether at one point, Ampex released the world’s first magnetic tape video recorder, the VRX-1000,

in April 1956. It caused a sensation. But with a price tag of US\$50,000 (equivalent to some US\$325,000 today), expensive rotating heads that had to be changed every few hundred hours, and the need for a highly skilled operator, it was far from a consumer item.

The orders from the television networks, however, came pouring in. CBS was the first to use the new technology, airing *Douglas Edwards and the News* on November 30, 1956, from New York then replaying the broadcast from its Hollywood studios a few hours later. From that day on, Edwards never had to repeat a broadcast, and television changed forever.



April 14, 1956. Ampex’s Charles Anderson described the scene when the VRX-1000 unveiling ceremony was played back to the audience moments after the event: “There was a deafening silence.

Then came a roar. People started to swarm back around the machine.”

Fast-forward to home video

The other companies abandoned their research and followed Ampex’s lead. RCA pooled patents with Ampex and licensed in the Ampex technology. The new goal was to develop a video machine for home use. It had to be solid, low-cost and easy to operate.

Sony released a first home model in 1964, followed by Ampex and RCA in 1965. While these machines, and those that followed over the next 10 to 15 years, were much less expensive than the VRX-1000, they remained beyond the means of the average consumer,

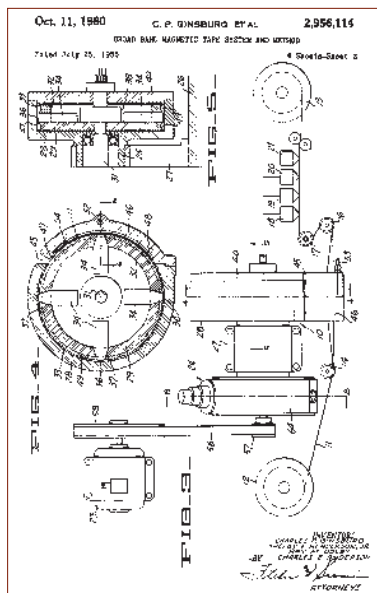

U.S. patent 2,956,114 for a “Broad Band Magnetic Tape System and Method,” was granted to Charles Ginsburg, known as the father of the video recorder, who led the research team at Ampex Corporation.

New communications technology — then as now — has always challenged previous assumptions and jurisprudence in the area of copyright.

Quote...Unquote

When giving testimony in front of the U.S. Congress in 1982, Jack Valenti, then President of the Motion Picture Association of America, famously stated: "I say to you that the VCR is to the American film producer and the American public as the Boston strangler is to the woman home alone."

He need not have worried. In 2001, the best year on record for the home video industry, the Video Software Dealers' Association reported that U.S. consumers spent a whopping US\$7 billion on video rentals and US\$4.9 billion on video purchases.

and were bought primarily by wealthy customers, businesses and schools. But the consumer electronics industry could feel the first tremors of VCR revolution and everyone wanted a piece of the pie. Fortunes were sunk into further research and development.

The competition between the companies led to the release of three different, mutually incompatible VCR formats: Sony's Betamax in 1975, JVC's VHS in 1976, and the Philips V2000 in 1978. Two of these would come head-to-head in the 1980s in what became known as the first Format War.

Before the technology battle could begin, however, the consumer electronics industry had to find an answer to a more pressing problem: content. Where would it come from? What would people watch on their VCRs? At this stage, the industry regarded the VCR's television recording feature as a bonus option of little utility to the average home user. — Why, they asked, would anyone want to record a TV show and watch it later? They thought movie videos would provide an answer to the content problem. But the studios had something to say about that.

Pause – The copyright challenge

Home video sent the movie industry into a spin. Television had already stolen a big part of their market, and they saw the VCR as a massive new threat.

Copyright, they argued, was at stake. Did not the mere recording of a television show constitute an infringement of the copyright owner's rights over reproduction? The studios took the issue to court. In 1976, the year after Sony's release of the Betamax VCR, Universal City Studios and the Walt Disney Company sued Sony, seeking to have the VCR impounded as a tool of piracy.

New communications technology – then as now – has always challenged previous assumptions and jurisprudence in the area of copyright. Just as the printing press, by making possible the mass reproduction of books, led to the first copyright laws, and cinematography raised the question of authors' rights to derivative works, now it was the turn of the VCR. The first court decision in 1979 went against the studios, ruling that use of the VCR for non-commercial recording was legal. The studios appealed and the decision was overturned in 1981. Sony then took the case to the U.S. Supreme Court.

In a landmark judgement in 1984, the Supreme Court ruled that the home recording of television programs for later viewing constituted "fair use." An important factor in the Court's reasoning was that "time-shifting" – i.e. recording a program to watch it at another time – did not represent any substantial harm to the copyright holder, nor did it diminish the market for the product.

1. U.S. Supreme Court
SONY CORP. v. UNIVERSAL CITY STUDIOS, INC.,
464 U.S. 417 (1984) 464
U.S. 417





In 2001, U.S. consumers spent US\$7 billion on video rentals and US\$4.9 billion on video purchases.

By then, the VCR had become a popular consumer product, and, contrary to their fears, the film studios found themselves to be major beneficiaries of the technology as the sale and rental of movie videos began generating huge new revenue streams. In 1986 alone, home video revenues added more than US\$100 million of pure profit to Disney's bottom line. The television stations, on the other hand, having found that the "useless" recording option was a big hit with viewers, faced a different problem. They had to find new ways to keep their advertisers happy now that viewers could fast-forward through the commercial breaks.

Betamax versus VHS: the battle to set the standard

Meanwhile, the format war between VHS and Betamax was underway. When Sony released Betamax, they were confident in the superiority of their technology and assumed that the other companies would abandon their formats and accept Betamax as the industry-wide technical standard. They were wrong. On their home turf in Japan, JVC

refused to comply and went to market with their VHS format. In the European market, Philips did not play along either, but technical problems were to take Philips out of the fight almost before it began.

From where Sony stood, the only clear advantage of the VHS format was its longer recording time. So, Sony doubled the Betamax recording time. JVC followed suit. This continued until recording times were no longer an issue for potential customers, and marketing overtook superior technology as the key to the battle.

The two companies were on a par for several years until JVC's VHS format pulled ahead. This was due in part to JVC's broader licensing policy. Counting on increased royalties to make money on their VHS machines, JVC licensed the technology to big consumer electronics companies like Zenith and RCA. As a result, VHS machines became more abundant on the market and prices fell, increasing their consumer appeal.

At about the same time in the early 1980s, video rental shops started springing up on every street corner. Early on, the video shop owners recognized that they would have to make VCRs available for cheap rental to attract a larger client base. The high-quality Betamax machines were more expensive, harder to repair, and the first models were only compatible with certain television sets. So VHS became the obvious choice for the rental shops. The domino effect – greater availability of VHS machines leading to more VHS video releases – eventually squeezed out Betamax.

Press eject

Technology, of course, did not stand still. Already by 2003 DVD sales had overtaken those of the VCR, signaling the dying days of magnetic tape. Video

rental shops, sensitive to market trends, switched to DVD, accelerating the demise of the VCR. And so it continues, as providers of the latest digital video recorders, of film streaming to mobile telephones and of other new technologies tumble over each other to offer consumers ever more options.

Nor have all related copyright issues been resolved. The digital revolution of communications media will continue to pose new challenges for copyright. Complex questions ranging from the use of digital rights management, to the exceptions and limitations that define fair use of copyrighted works, con-



Photo: Sony

Photos.com

The portable camcorder was a logical development from the VCR. Early models were bulky. It was easy to miniaturize the cameras, but the recorders were more difficult. The solution: miniaturize the magnetic tape.

tinue to fuel international debate in policy and legal norm-setting fora, so contributing to the ongoing evolution of copyright law and practice.

Fair Use, Fair Dealing, Statutory Exceptions

A crucial element of copyright law concerns the exceptions which limit its reach, i.e. the various uses of copyrighted works that do not “conflict with a normal exploitation of the work,” nor “unreasonably prejudice the legitimate interests of the author,” as stated in the Berne Convention, and which give the public a certain leeway in making free use of the work.

Such uses are commonly enumerated as *fair dealing* categories in some common law jurisdictions, and as *statutory limitations and exceptions* to copyright in civil jurisdictions. In addition, there is a concept known as *fair use*. Established in the legislation of the United States of America, the fair use doctrine allows the use of works without the authorization of the rights owner, taking into account factors such as: the nature and purpose of the use, including whether it is for commercial purposes; the nature of the work; the amount of the work used in relation to the work as a whole; and the likely effect of its use on the potential commercial value of the work.

The interpretation of exceptions has changed over time, as in the VCR case, and will continue to evolve as new technologies open up new possibilities.

Exceptions may exist in various areas, such as:

- public performance, e.g. for music played in religious services;
- broadcasting, e.g. for the television transmission of an art work caught on film incidentally during a news report;
- reproduction, e.g. the VCR “time-shifting” exception; or copies of a small part of a work made by a teacher to illustrate a lesson; or quotations from a novel, play or movie.

INNOVATION TO DRIVE DEVELOPMENT

A South African Perspective

By Dr. Sibongile Pefile



The smart-lock safety syringe provides improved protection against needle stick injury and contamination.

Dr. Sibongile Pefile is responsible for Research and Development Outcomes at the South African Council for Scientific and Industrial Research (CSIR). In this article for WIPO Magazine she explores how innovation can be fostered to further socio-economic development in developing countries, and she highlights some recent South African innovations which illustrate this.

At the CSIR, our business is to foster industrial and scientific research and technological innovation in collaboration with the private and public sector in order to contribute to improving the quality of life of the people of South Africa. Our focus is on promoting and transferring innovative technologies and scientific knowledge in a sustainable manner, with an emphasis on technologies that have a high potential for impacting positively on communities.

Innovations and inventions

So what does this mean? And how does a developing country like South Africa create the conditions necessary to stimulate – and benefit from – the innovative capacity of its institutions and people? It does no harm to start at the beginning and take a moment to consider what is meant by innovation. A useful way of looking at it is that creativity is the generation of new ideas, inventions are new discoveries that can be patented and provide a solution to a problem, while innovation is their commercialization and exploitation. Therefore, innovation is the application of the solution in society or the economy. It is possible to be innovative, yet never invent anything.

The CyberTracker

A hand-held computer, connected to a satellite navigational system, provides a high-tech method of tracking animals in the field. Invented in 1996 by environmentalist Louis Liebenberg and Lindsay Steventon, it combines traditional tracking skills with state-of-the-art computer and satellite technology.

CyberTrackers are currently being used in major parks such as the Karoo National Reserve to map animal movements and breeding patterns as part of a major conservation project. A graphic interface enables illiterate trackers to enter detailed information, so helping scientists to carry out their research.



Rolex Award for Enterprises/
Photographer Eric Vandeville

Systems of innovation

Much work has been done to study the different elements which combine to facilitate innovation in a given sector. For innovation to occur, scientific, business and institutional knowledge is required from different sources. So a “system of innovation” is based on a network within an economic system, which connects the different organizations or stakeholders involved in the creation, adoption, use and diffusion of scientific and technological knowledge. The context and institutions involved govern the nature of the interactions and processes that take place in a system of innovation. Innovation results from this interactive process between such stakeholders. It is not a linear process, but an iterative process with feedback loops between the different stages.

To promote a system of innovation requires:

- support for R&D;
- an active public sector;
- manufacturing, trade and industry capability;
- creation of domestic markets;
- development of export markets;
- creation of intellectual property systems;
- creation of the appropriate policy environment.

The Mine Burner

Developed with funding from the CSIR and the Department of Trade and Industry, the MineBurner aims to slash the costs of de-mining operations and reduce the deaths caused by landmines worldwide. The device burns up the explosive compound in the mine, rather than exploding it, making it safe to use in built-up areas.

The inventor, Paul Richards, explains: "MineBurner uses patented pressure technology to deliver exactly the right amount of oxygen and LPG (cooking gas) at the right pressure to burn out the mine. It uses materials which can be sourced and manufactured locally, thereby cutting down cost." The UN estimates the cost of removing a landmine using traditional methods at between US\$300 and US\$1,000. The equivalent cost using the MineBurner is estimated at only 20 cents.



These determinants are dynamically linked, in that progress in one is facilitated by progress in all.¹ And similarly, a lack of progress in one impedes progress in others. So a coherent strategy for innovation should address each of the determinants. Simply put, the innovative performance of an economy depends not only on the performance of each determinant, but on how they interact with each other as elements of a collective system.

The innovation chasm

Some noteworthy innovations have originated from South African institutions as these pages show (see images). But how much more creativity lies untapped, or has fallen into what has become known as the *innovation chasm*?

When one looks at the process through which inventions and discoveries are brought to market, the R&D phase is often funded using public money. Once a product has been developed and tested, private sector investment funding, ideally, should take over. In the absence of early technology investors, the problem is, who pays for the cost of development work, such as testing prototypes, developing the business plan, or for the transfer of know-how associated with a technology? This funding gap, or innovation chasm, is the gap between, on one side, research, and on the other side, the application of products/services created from technologies developed from such research. Many developing countries with moderate R&D activity suffer from an innovation chasm because they fail to bridge the gap between knowledge generation and knowledge application.

Social issues

Technology transforms the way in which we do business and lead our lives. Difficult tasks can become simpler when innovative products and

processes are applied. But most new technologies are still not reaching those who most need them. Access continues to be limited by factors such as the cost of new products, and the fact that the private sector, in the interest of shareholders, is more concerned with investing in products that have potential for high returns rather than good social impact.

Increasing the capacity to innovate to improve the human condition of the poor is our most important challenge. A simple initiative such as bringing clean water and sanitation to homesteads significantly reduces disease and saves lives in developing countries. Innovations do not always have to be sophisticated to be effective and have impact. What is important is that they must be appropriate and reach the communities that need them most – in the way that the Play Pumps (page 14) have transformed the lives of some South African rural communities.

IP can be an emotive issue in the context of creating an enabling environment for socio-economic development in developing countries. But international IP laws exist, as do national IP laws now in many developing countries, and the way I see it, we should be asking, how can IP be managed creatively in order to benefit from it? For developing countries to benefit from IP rights systems requires capacity and awareness building so that decisions, such as whether or not to patent, or to whom and how to license, are made from a knowledgeable standpoint.

Innovation to bridge the development gap – challenges ahead

Is it realistic to expect developing countries to grow in the same leaps and bounds as developed countries that have benefited from a series of significant

1. Adapted, R Mahoney, MIHR, 2003

But most new technologies are still not reaching those who most need them.



technological innovations over centuries? To do so they must meet the following challenges:

- **Finance.** The challenge for developing countries involved in R&D is to bring to market the stream of new, improved or added-value products or services. In the present situation, it is more difficult for developing country governments to allocate funds to initiatives that, often, have intangible, long-term outcomes.
- **Managing innovation.** In order to derive benefits from the innovative capacities of R&D institutions, one needs to build institutional capacity to transfer technology from the lab to the market. Once in the market, the technology should go through acceptance and adoption, widespread diffusion and, ultimately, its demise as other technologies take over the industry.
- **Education and training.** For many institutions, managing innovation is an emerging area. A major challenge for any research organization, whose aim is to pursue research, is to find ways to transfer their ideas into practical advances – in other words to be effective in technology transfer. Innovation management requires multidisciplinary teams capable of breaking down the barriers that stand in the way of technology adoption. To achieve this, education, training and practical experience is key.
- **Time.** Various actors and social groups play a role in the diffusion of innovation. Innovation is a process which takes time to show tangible results and for its impact to be felt. These time factors have to be taken into consideration.

When Innovation is Child's Play

At the end of another school day in Acornhoek – a rural community in the semi-arid eastern part of South Africa – children shriek with laughter as they whirl each other around on a colorful merry-go-round. Women carry home buckets of water. Boys chase a football.

But there is more to this scene than meets the eye. Forty meters under ground, each turn of the merry-go-

round powers a pump. At 16 rotations per minute, it pumps water effortlessly to a 2,500-liter storage tank, supplying the needs of the entire community at the turn of a tap.

The storage tank above the children's heads displays four billboards. These carry educational, public health and HIV/AIDS-prevention messages, as well as commercial advertising, generating enough revenue to fund ten years' maintenance of the system.

The idea was first dreamt up by engineer and bore-hole-driller, Ronnie Stuiver. As he traveled the country drilling wells, fascinated children would crowd round him – most with boundless energy and few outlets for play. He devised a merry-go-round attached to a simple pump. It worked. But it took the

entrepreneurial vision of advertising executive Trevor Field, who stumbled across the pump at an agricultural fair in 1989, to transform an ingenious invention into an innovative, sustainable solution to one of the region's most pressing problems.

Turning point

With two business colleagues, Mr. Field licensed the concept from the inventor and launched Roundabout Outdoor. They developed and patented the PlayPump™ water system. For years it remained a small venture. Then in 1999 President Nelson Mandela opened a new school with a PlayPump merry-go-round and took a spin on one. The press photos captured the imagination of donors and investors. A collaboration began to flourish between the PlayPumps International non-profit organization and big business and government sponsors. The following year, Roundabout Outdoor won the World Bank Development Marketplace Award, bringing extra visibility and new funds.

Today, some 700 PlayPump™ systems are installed in disadvantaged communities across South Africa, Mozambique and Swaziland, transforming the lives over a million people.

Take Boikarabelo village, for example. Journalist Kristina Gubic describes the scene: Two hours drive from Johannesburg, Boikarabelo is home to 700

Photo: Courtesy of PlayPumps International

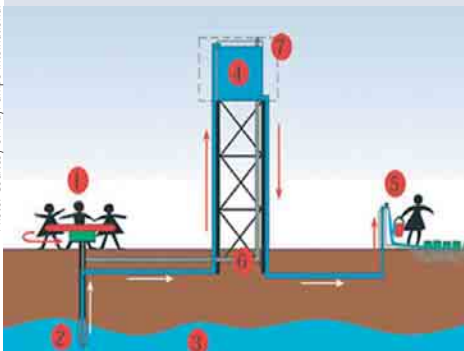

- **Critical mass.** It is essential to attain a critical mass in areas of strategic research and socio-economic development. The right skills must be developed to identify and exploit inventions and discoveries for societal benefit and economic gain, and to build research capabilities to enable the production of new or improved technologies.
- **Sustainability.** In an environment of scarce and precious resources, the issue of sustainability is of great significance. Technologies need to address industry and community needs in a sustainable manner.
- **Leadership.** Leadership in the creation of new technology is of prime importance, and nobody will be surprised to hear of the tensions that exist between the ambitions of a creative scientist, the demands of the market and the availability

of resources. Leadership is required to ensure that such tensions are managed and that the focus is on progress.

- **Measuring impact.** How will we know whether or not the outcomes of R&D are making a difference in the world today? Measuring impact will ensure that we remain on track of set objectives and are accountable for delivery and the use of scarce resources.

Our challenge is to ensure that innovation is encouraged at all levels of the economy, and that the impact is positive on society. One way to achieve this is by opening the door to those who, in the past, have not been able to participate in the economy in a meaningful way. A challenge indeed!

Photo: Frimmel Smith



The boys of Boikarabelo wash in the water they pumped while playing. Access to clean water means better hygiene and sanitation so less disease.

Photo: Courtesy of PlayPumps International



An hour's play produces up to 370 gallons of water. The billboards carry public health messages and generate advertising revenue to fund maintenance.

people living in corrugated iron shacks. Before, the residents had to walk across boulders and grasslands to the edge of a farm to collect water from an underground spring. Just carrying the minimum for cooking and washing was exhausting work. Today, each family has a vegetable garden and laundry hangs everywhere. The school is constructing greenhouses to make it independent of the sporadic donations on which school meals used to depend. With cabbages, spinach and beans to supplement the maize diet, the children's nutrition has improved dramatically.

The economic and social impact reaches further. Clean water prevents the diseases which kept children from school and parents from work. Freed

from the daily toil of water-carrying, girls have time for education; and the women elders of Boikarabelo have started a small craft business. Across the street, another resident has begun raising chickens, which he sells to the local supermarket. "Being able to bring them fresh drinking water and to wash out their cages makes them healthy so I can fetch a good price," he says.

The project continues to gather speed. If PlayPumps International achieve their goal, they will have to reach 10 million people throughout Sub-Saharan Africa within the next three years. (More information: www.playpumps.org)

PCT PORTRAITS

More than 1.2 million international patent applications covering new technology of every description have been filed since the Patent Cooperation Treaty (PCT) began operating in 1978. Continuing our series of snapshots, WIPO Magazine dips into the database of PCT applications and seeks out the people behind the patents. In this edition we find three very different inventions with medical applications

Nobel Prize for the Silence of the Genes

Photo: Robert Cahilly/
Copyright University of Massachusetts Medical School



The discovery by Craig Mello (left) and Andrew Fire was “like opening the blinds in the morning,” said a Nobel committee member.

At 4:40 am on October 2, 2006, Craig Mello in Massachusetts was going back to bed after checking his diabetic daughter’s blood sugar level when the phone rang. At a similar hour in California, Andrew Fire was woken by what he assumed was a wrong number call. The phone calls – from Sweden – informed the two scientists that they had been jointly awarded the 2006 Nobel Prize for Medicine.

In 1998 Dr. Craig Mello and Dr. Andrew Fire discovered a fundamental mechanism for controlling the flow of genetic information in living cells, solving a puzzle that had baffled scientists in different disciplines for years. They found a way to silence – or switch off – specific genes by disabling the gene’s “messenger” RNA molecules. RNA (ribonucleic acid) is similar to DNA, but more active and performs many of the cell’s more difficult

tasks, such as instructing a gene to produce a protein. It is by making proteins that an individual gene produces its effect. By silencing this effect, it is possible to identify the function of specific genes.

In the few years since they published their findings, RNA interference has become an essential research tool with multiple applications. In his interview for *Nobelprize.org*, Dr. Fire cited a study in Holland, “where they used RNA interference to characterize a given tumor type. Once they figured it out they said, ‘You could treat this with aspirin!’” Biomedics are also now using RNA interference to try to switch off disease-causing genes, with the aim of developing a new class of pharmaceuticals with the potential to treat diseases from diabetes and flu to AIDS and cancer.

Andrew Fire, who was working at the time for the Washington-based Carnegie Institution, and Craig Mello, at the University of Massachusetts Medical School, did their groundbreaking experiment in a tiny worm, the *C. ele-*

gans. They found they could block the effect of a specific gene by injecting worms with a double-stranded RNA. A friend and colleague of Andrew Fire’s, geneticist David Schwartz, recalls the hours of unglamorous labor that went into the research: “I’d be working in the middle of the night and Andy would be hunched over his microscope next door, feeding his worms. He had to push food their way with a tiny brush.”

Both scientists stress that they provided just one key piece of a jigsaw to which numerous researcher had contributed throughout the world. “Science is a group effort,” Andrew Fire told reporters.

Andrew Fire, Craig Mello and their research colleagues filed PCT applications in 1998 and 2000 for “genetic inhibition by double stranded RNA” and for “RNA interference pathway genes as tools for genetic interference.”

More information:
<http://nobelprize.org/>

Metal Magician Meets Engineering Wizard

A hypodermic needle so fine that it makes injections pain-free. This was the challenge proposed by the Tokyo-based medical equipment manufacturer, Terumo Corporation, with the goal of alleviating the daily discomfort of insulin injections for diabetic children. It was met by bringing together Terumo’s engineer, Tetsuya Oyauchi, who has a string of patents to his name for medical syringes, and Masayuki Okano, the 73-year old head of a small metal pressing factory.

The usual method of manufacturing needles is to hollow out a tiny cylinder of metal. But the thinner the cylinder, the more difficult this procedure becomes. Terumo Corporation’s quest for an ultra-thin needle had been turned down as impracticable by a string of large metalwork firms, before they turned to Mr. Okano, whose skilled craftsmanship, *Web Japan* reports, had earned him a reputation as a metalwork magician.

"I thought if no one else can do it, I will," said Mr. Okano. He tried a different approach, defying experts who had advised him that it was not possible. Taking a super thin sheet of stainless steel, he rolled it into a tiny tapered cylinder, then sealed it by welding the seam.

Courtesy of Terumo Corporation



"You won't feel a thing..."

Refined and developed with the medical engineering expertise of Tetsuya Oyauchi, Terumo's PCT application for a tapered "injection needle and liquid-introducing implement" was published in 2004. The resulting product, the *Nanopass 33* syringe, went on the market in July 2005. Terumo claims that the tip, which measures just 0.2 millimeters across – no

wider than two strands of hair – is 20 percent thinner than conventional needles, and that it reduces discomfort to no more than a mosquito bite.

The *Nanopass 33* needle was awarded the 2005 Grand Prize for Good Design by the Japan Industrial Design Promotion

Organization, winning the award by a wide margin of votes. "It is fun to make something that doesn't exist in the world," commented Mr. Okano.

More information: web-japan.org/trends/science/sci051220.html

Pills from Poisons

Take one part venom from the rough-scaled snake; mix with scientific brains from the National University of Singapore (NUS); pass through a well-oiled technology transfer office; and sprinkle liberally with entrepreneurial flair. The result? Pro-Therapeutics, a Singaporean start-up company, set up to develop novel therapeutic drug products based on peptides derived from animal toxins.

Among the products in the pipeline are a pain-killer peptide derived from king cobra venom, which has analgesic properties said to be several thousand times more potent than morphine; an anti-coagulant peptide, derived from the venom of the Australian rough-scaled snake, which prevents the formation of blood clots; and an anti-angiogenic peptide which inhibits the spread of blood vessel cells, for treatment of cancers and eye diseases.

Professor R. Manjunatha Kini, a protein chemist at the NUS Department of Biological Sciences, is the company's chief scientific officer and a co-founder. Well attuned to the value of intellectual property, he has had seven PCT applications published in the last eight years.

Professor Kini's fascination with poisonous snakes stemmed from a childhood spent in India. This was to inspire his life's work, devoted over 27 years to studying venom from some of the world's most lethal reptiles in a quest for new ways to fight human afflictions. "Snake venoms are unique cocktails of pharmacologically active proteins and peptides," Professor Kini explains. "Some of these toxins help us in deciphering the molecular mechanisms of normal physiological processes. Some can also help in developing therapeutic agents for the treatment or prevention of human diseases."

But the nature of these proteins is such that, to date, they have been limited to use in treatments delivered by injection. Now, using patented technologies licensed from the NUS, the Pro-Therapeutics team is working to re-engineer the proteins in order to produce small novel peptides that can be administered as pills. The breakthrough, when it comes, will open up a growing market for peptide therapeutics estimated in 2003 at US\$9 billion.

More information: www.protherapeutics.com

Courtesy of Peter Mitschin, Venom Supplies Pty Ltd



A peptide derived from the venom of the king cobra may produce a pain-killer several times more potent than morphine.

TRADEMARK COEXISTENCE

Trademark coexistence describes a situation in which two different enterprises use a similar or identical trademark to market a product or service without necessarily interfering with each other's businesses. This is not uncommon. Trademarks are often used by small businesses within a limited geographical area or with a regional customer base. Almost every French town with a train station, for example, has its own *Buffet de la gare* restaurant. Often trademarks consist of the family name of the person who started a business and, where that name is a common one, it is not unusual to find similar businesses under the same or similar names. None of this need lead to conflict or litigation, as long as the trademarks in question continue to perform their main function, namely to distinguish the goods or services for which they are used from those of competitors.

The problems start if this distinguishing function no longer works because the businesses for which the trademarks were originally used begin to overlap. Thus trademarks which had happily coexisted at one time may suddenly enter into a conflict. This is particularly frustrating where both businesses use their identical trademarks in good faith - in other words, where both have a track record of real use of their respective brands, but because of business expansion start to trespass on each other's territories. In some cases, when two companies are aware that they are using similar or identical trademarks, they may choose to conclude a formal co-existence agreement in order to prevent the future use of the two marks overlapping in such a way as to become undesirable or infringing. This article outlines situations in which coexistence may arise, and introduces some points to bear in mind when considering a coexistence agreement.

It should be stressed that prevention is better - and cheaper - than cure. One of the most basic precautions when selecting and registering a new trademark, is to undertake as comprehensive a search as possible, using professionals skilled at the task. A thorough trademark search should minimize the risk of a business coming face to face with a similar mark once on the market. But no search is infallible. Identical or confusingly similar trademarks may sub-

sequently be found to exist if the search net was not cast widely enough, or if it did not include other categories of goods and services which might turn out to affect the viability of the proposed mark. Similarly, a search might overlook *unregistered* marks, as in many countries well known trademarks are protected even if they are not registered.

It frequently happens that two traders find themselves using the same or a similar trademark with respect to the same or similar goods in different parts of the world. They may remain genuinely unaware of each other's existence for years until one of them expands the business and starts using the trademark or files a trademark application in the country in which the other operates.¹ What happens then? At that point, a trademark office may refuse the application on the grounds that it conflicts with the earlier rights acquired by the other trader. The latter may also object to the application in the course of opposition proceedings, or bring an invalidation action after the mark has been registered.

In certain common law jurisdictions, the concept of "honest concurrent use" may apply. This takes into account the nature and length of use, the geographical area of trade, and the honesty of the adoption and subsequent use of the mark. A long period of concurrent use (at least five years) may help to overcome an opposition, and allow the two marks to coexist. However, a finding of honest concurrent use depends on a number of factors, including the likelihood of consumer confusion. Cases in which both parties are granted registration with, for example, a delimited geographical area of use for each company's mark, seem therefore to be an exception rather than the rule.

"Come Together"

In a formal trademark coexistence agreement both parties recognize the right of the other to their respective mark and agree the terms on which they may exist together in the market place. Such coexistence may be based on a division of the territories in which each holder may operate, or on a delimitation of their respective fields of use, i.e. regarding the goods or services on which they are used.

1. Regarding the use of trademarks on the Internet and the question of commercial effect of such use in a given country, see the Joint Recommendation Concerning Provisions on the Protection of Marks, and Other Industrial Property Rights in Signs, on the Internet, WIPO publication No. 845.

If a coexistence agreement is the best option, the first step is for the two enterprises to delineate their respective areas of business and agree to stick to those parameters. The real challenge, however, lies in anticipating the future development of each company's activities. Where would each company like to see itself in ten or twenty years' time? Will their respective expansion risk converging on each other's territories?

The case of Apple Corps, the record label founded by the Beatles, and Apple Computer² illustrates the difficulties (see WIPO Magazine 4/2006, p. 23). The two companies entered into a trademark coexistence agreement in 1991. This provided that Apple Computer would have the exclusive right to use its Apple marks "on or in connection with electronic goods, computer software, data processing and data transmission services"; while Apple Corps would have the exclusive right to use its own Apple trademarks "on or in connection with any current or future creative work whose principle content was music and/or musical performances, regardless of the means by which those works were recorded, or communicated, whether tangible or intangible." Thus, although the two companies had confusingly similar trademarks, they identified an area in which they were distinct – i.e. fields of use – and this became the basis of their coexistence agreement. The agreement permitted the two companies to continue to do business and build on their reputations without infringing on each other's rights.

But neither company foresaw that the future development of digital music technologies was to bring the two fields much closer together. When Apple Computers launched the iPod and the iTunes software and music store, Apple Corps sued, claiming that Apple Computers had trespassed into the area exclusively reserved for Apple Corps, thus contravening the trademark coexistence agreement. The court looked at the issue from the point of view of the consumer and held that there had been no breach of the agreement as the Apple Computers logo had been used in connection with the software and not with the music provided by the service. No consumer downloading music using the iTunes software would think they were interacting with Apple Corps.

Despite the coexistence agreement, expensive litigation was not avoided in this case. As in all agreements, therefore, it is advisable to include a clause on dispute settlement for when problems arise in the future. The WIPO Mediation and Arbitration Center offers some useful examples of such clauses.³

Public interest and anti-trust

An important question to be considered before negotiating a coexistence agreement is that of public interest. A court may invalidate an agreement if it considers that the coexistence of similar trademarks in a particular case would be against the public interest. This may arise notably in the area of public health if two different medical products bore the same trademark – even if the companies operated in distinct geographical areas.

Companies should also be aware of competition and anti-trust regulations: the courts could find that their confusingly similar trademarks for similar products affect competition in the marketplace.

The process of choosing a trademark must be carried out with caution and foresight, undertaking as comprehensive a search as possible, preferably with the assistance of a specialist. If despite these efforts a conflict arises with the same or a similar trademark in the market, then an agreement to coexist may prove less expensive than legal confrontation. While this is not to say that faced with litigation it is always better to capitulate and agree to coexist, litigation may be the only appropriate response in some situations. It is for the owners of the trademarks to judge in each case what would be the appropriate response in light of their particular situation.

2. See High Court of England and Wales, Apple Corps. Limited vs. Apple Computer, Inc., decision of 8 May 2006, [2006] EWHC 996 (Ch). For the text of the decision see www.hmcourts-service.gov.uk/judgmentsfiles/j4226/apple_v_apple_hc03c02428_0506.htm.

3. See www.wipo.int/amc/en/mediation/contract-clauses/index.html

CYBERSQUATTER OR INNOCENT FAN?

The Wayne Rooney Domain Name Dispute

In just seven years of operation, WIPO's Arbitration and Mediation Center has dealt with 25,000 domain

name disputes, and the cybersquatting phenomenon shows no sign of abating. So what happens in a typical case? In this article, WIPO Magazine takes a look at the

decision in a case issued in October 2006, which was brought by England football star Wayne Rooney.¹

The line-up

The respondent, a Welsh television actor who described himself as an ardent fan of Everton football club, had registered the domain name *waynerooney.com* together with *waynerooney.co.uk* in April 2002. At the time, Wayne Rooney was a promising but little known 16-year old player. Six months later, he scored a spectacular goal against Arsenal, making headlines as the youngest goal-scorer in the history of the Premiership.

The case was filed under the WIPO-initiated Uniform Domain Name Dispute Resolution Policy (UDRP) by Wayne Rooney and his management company, which owns a trademark for the words Wayne Rooney, published in August 2004. The disputed domain name was being used to connect to a directory run by the service provider, from whom the complainants assumed the respondent was deriving income.

The defense

The respondent denied the allegations. He argued that his domain name pre-dated Rooney's trademark, and that no unregistered rights existed in 2002 when Rooney was only known locally. He stated that he had registered the name in good faith after watching Rooney play, with the intention of setting up a non-commercial fan site. But, he said, he had never got around to doing so, because he lacked the necessary know-how and was busy with his acting career. After Rooney "betrayed" Everton by moving to Manchester United in August 2004, the respondent explained that he had lost interest. He said that he had not known that the domain name had been linked to a commercial directory until he received the complaint, at which point he had requested that the link be removed.

Referee

WIPO appointed Mr. Tony Willoughby, a London based IP practitioner, to decide the case.

How did the panel decide? First, on the claim that the domain name pre-dated Rooney's registered trademark, the panel referred to the Overview of WIPO Panel Views on Selected UDRP Questions,² which states that registering a domain name before a complainant acquires rights does not preclude the finding of trademark rights in a UDRP case.

Had Rooney acquired sufficient reputation, or "goodwill," by April 2002 to amount to unregistered trademark rights in his name? Yes, concluded the panel, noting that, while not yet having acquired national fame, Rooney was already well-known in the Liverpool area, featuring regularly, for example, in *Liverpool Echo* headlines such as "No Rest for Blues Hotshot Rooney."

Had the respondent registered the domain name in bad faith for commercial gain? The panel deemed the respondent's account of his "legitimate rights" in the domain name as an ardent fan "difficult to swallow." Without any knowledge of web design, the panel noted, he claimed to have developed an urge to register two domain names in order to create a fan site for a little known 16-year old footballer, but then had done nothing to further this intention. The panel visited the two fan sites that the respondent had cited as examples of what he had intended to do with his Rooney domain. Both were commercial sites.

The panel concluded that the respondent had anticipated that Wayne Rooney would become hot property and had registered the domain names in the hope of extracting commercial benefit. This constituted a registration in bad faith, regardless of the fact that he had never got around to using the domain name. The panel ordered that the domain name be transferred to Wayne Rooney and his management company.

Photo: Wikipedia



**Footballer
Wayne Rooney**

1. www.wipo.int/amc/en/domains/decisions/word/2006/d2006-0916.doc
2. www.wipo.int/amc/en/domains/search/overview/index.html

TEACHING COPYRIGHT TO TEENAGERS

How does one set about teaching a classroom full of teenagers about copyright? Lecture them on the legalities, and you will be met with yawns. Quote financial figures showing music industry losses caused by downloading, and the response will be cynical. Preach ethics, and you may be told that you are out of touch with the “sharing generation.”

In a project undertaken as part of a Masters degree in Intellectual Property (IP), sponsored by the Spanish PRISA media group and the Carlos III University in Madrid, a group of graduate law students took themselves into the classroom to discover what sort of approach makes this challenging audience sit up and listen. Two of the students, Raquel Pérez Alberdi from Spain, and María Valeria Rapetti Tizze from Uruguay, described their observations to WIPO Magazine.

“In Spain, 99 percent of young people between the ages of 15 to 19 listen to music, according to surveys published in the 2005 Yearbook of Cultural Statistics” explained Ms. Rapetti. The students observed widespread illegal copying among teenagers, combined with little understanding and much misinformation about copyright. “So it seems clear,” they concluded, “that educating this age group about the legal, ethical and economic issues underpinning copyright is critical in reducing piracy.”

Putting a human face on copyright

They began by looking at what they saw as some key questions: Why do so many young people feel that music or images in digital form should be free, while accepting that it must be paid for in physical format? What is the source of the antipathy commonly expressed by young Spanish consumers towards collective management societies? Why is there a perception that IP in the music industry only serves the interests of big businesses?

Their research suggested that young people tended to view piracy as socially acceptable largely because it seemed impersonal. People had little sense that their own actions in downloading or copying music illegally would impact on the individual creators and industry workers whose labor went into producing each song.

The challenge for IP education, they concluded, was to present copyright in such a way that young consumers could relate to those whose livelihoods depended on it. This meant getting away from popular images of “fat cat” record companies and stars with million dollar hits. Instead, the face of copyright should be represented as the vast majority of ordinary artists and musicians who depend on their copyright-related earnings in the same way that any other worker depends on being paid for his or her work. The picture should be widened to include the vast numbers of people who work in the copyright-based industries –



Classroom debate explored why many young people view piracy as socially acceptable.

be it in record shops, night clubs, CD manufacturing companies and so on. The sort of people, in other words, whom the average school student would know.

Ms. Pérez and Ms. Rapetti explained how they devised lesson plans and took them into classrooms to test them out. To spark discussion, they showed video footage of a call on a bar-owner by a representative of a Spanish collective management society. The former’s indignation at the notion that she should pay royalties on music she played in her bar, and the representative’s explanations as to why this was so, provoked lively classroom debate, which led in turn to a clearer understanding of the role of collective management.

Over the following months, the Masters students drew on their experiences to compile a comprehensive copyright teaching manual for use in secondary schools. They hope thereby to improve understanding among this avid group of music consumers of how copyright helps to keep the music playing.

NEWS ROUNDUP

WIPO Report Shows Internationalization of Patent Trends

The WIPO Patent Report 2006, released on October 16, shows that companies are increasingly using the IP system to protect their investments in new markets. The Report presents an overview of worldwide patenting activity based on statistics up to the end of 2004.

The number of patent applications filed worldwide almost doubled between 1985 to 2004, with an average annual rate of increase of 4.75 percent since 1995. This is in line with the average annual growth in world gross domestic product (GDP) of some 5.6 percent.

Five patent offices (United States of America, Japan, European Patent Office, Republic of Korea

and China) account for 75 percent of all patent applications and 74 percent of all patents granted.

The Report shows a boom in patent filings in northeast Asia over the past 20 years, reflecting the emergence of countries such as China and the Republic of Korea as major industrial economies. Patent filings by Chinese residents grew more than five-fold between 1995 and 2004, while filings by residents of the Republic of Korea increased three-fold. Other countries recording high rates of increase in patent filings during this period included Brazil, India and Mexico.

The Report highlights the popularity of the Patent Cooperation Treaty (PCT) as a tool for companies seeking broad-based patent

protection. The number of PCT applications grew at an average annual rate of 16.8 percent between 1990 and 2005 and topped 134,000 international applications in 2005. The PCT is now used in 47 percent of all international patent filings.

The comprehensive report in an easily accessible format shows the distribution of patent activity around the world and contains detailed information on some of the important trends of the patent system. Currently available on the WIPO website at www.wipo.int/ipstats/en/statistics/patents/patent_report_2006.html, the Report will also be available in print from the end of the year.

Superman Takes on DVD Pirates

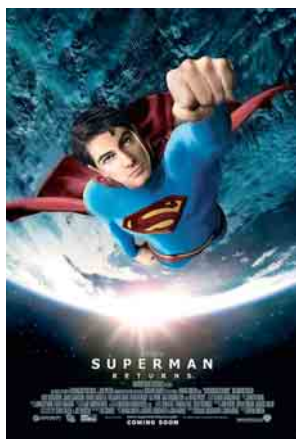

Fighting like with like. Warner Brothers' early release of the *Superman Returns* DVD, at a low price, is designed to win consumers back to the legitimate market.

Seeking to beat Chinese DVD pirates at their own game, Warner Brothers have released the DVD of Hollywood blockbuster *Superman Returns* two months earlier in China than in the rest of the world – and just three months after the film was first released in China. The film had pulled in 31.7 million yuan (over US\$4 million) at Chinese box offices during its first week and the manufacturers of pirate DVDs were anticipating massive demand.

Calculating that consumers buy pirated DVDs primarily because they are cheaper and because they do not want to have to wait for the legitimate product, CAV brought out their early release *Superman Returns* DVD in a low-cost version at 14 yuan (US\$1.77). While still not as cheap as the pirate copies, this offered consumers an attractively priced legitimate alternative.

The initiative also targeted distribution channels, pushing out beyond the big stores to put legitimate DVDs on the shelves of 8,000 retail outlets. Mark Horak, executive vice president and general manager of Warner Home Video, explained to the Reuters news agency: "Imagine walking through a city and every 100 yards or so is a little store that sells pirated products. The campaign we put together behind *Superman Returns* is intended to build out our distribution in those stores that previously only sold pirated products."

The initiative by CAV Warner Home Entertainment, a joint venture between Warner Home Video and China Audio Video, was supported by the Chinese government, whose "100 Day Campaign Against Piracy" ran from August to October.

Masters of Invention

A new Masters degree course at the University of Glamorgan in Wales, United Kingdom, due to start in 2007, will seek to equip aspiring inventors with the skills and knowledge to take their intellectual property out of the laboratory and into the market-place.



The course will prepare graduates for entrepreneurial careers in science and technology fields, says course leader Guiliano Premier.

The Masters in Invention and Innovation is conceived for graduates in engineering, sciences and technology who have an innovative idea for a new product or service which they believe has commercial potential. The program, to be based in the faculty of Advanced Technology, will combine modules from across the University, including intellectual property law, business planning and marketing, as well as research methodology and modeling.

“More often than not, good ideas are quietly forgotten in favor of a secure income from alternative employment,” says course leader Guiliano Premier. “With this course, students can uniquely gain an MSc qualification while indulging an ambition to develop a product or service and testing its commercial feasibility. The environment provides physical and intellectual resources that would otherwise not be available to the individual.”

The MSc has been championed by a panel of experts, including successful local inventors and representatives of the Wales Innovators Network. It is also supported by the Welsh Development Agency and other government bodies.

900,000 Trademarks Registered under the Madrid System

The 900,000th mark was registered in October under the Madrid System for the international registration of trademarks, the user-friendly and cost-effective system for the international registration of marks administered by WIPO. At the current rate of growth, it is anticipated that the one millionth mark under the Madrid system will be reached in 2009. The 900,000 milestone was registered by a Chinese company, seeking protection in ten countries for its *Gryphon* trademark, for use on glassware and ceramics. China, which became a member of the Madrid system in 1989, is now the eighth largest user of the system.



The largest share of the 33,565 international trademark applications received by WIPO in 2005 was filed by users in Germany (17.3 percent of the total), followed by users in France, the United States of America, Benelux, Italy, Switzerland, and the European Community. Applications from developing countries increased by 30.6 percent compared to 2004.

LETTERS AND COMMENT

WIPO Magazine welcomes letters commenting on issues raised in our articles, or on other developments in intellectual property. Letters should be marked "for publication in the WIPO Magazine" and addressed to The Editor at WipoMagazine@wipo.int or to the postal/fax address on the back cover of the Magazine. Please include your postal address. We regret that it is not possible to publish all the letters we receive. The editor reserves the right to edit or shorten letters. (The author will be consulted if substantial editing is required.)

Universities and technology transfer

Commercialization may not be the answer

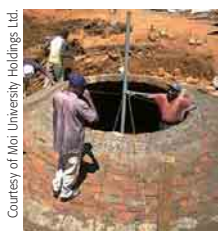

Courtesy of Moi University Holdings Ltd.

I write to take issue with the basic premise underlying your recent articles on the use of intellectual property by universities. (*Technology Transfer and Development; Putting Policies in Place. Issue no. 2006/5*)

The fundamental question for a public university's IP policy should not be: 'How can the commercial potential of the property be maximized?' but: 'How can the transfer of new ideas be maximized?' Commercializing IP is only one, and often the worst way to transfer new ideas. Concentrating on commercializing IP encourages universities to over-value their property leading to protracted negotiations through lawyers and other intermediaries which frustrates rather than facilitates the free flow of ideas necessary for research and innovation to flourish.

Revenue from licensing IP in fields other than biotechnology is a trivial proportion of university revenue. And of course, licensing revenue isn't all surplus or 'profit' – commercialization units are very expensive with their business development managers, IP lawyers and accountants. They also impose heavy indirect costs on researchers in explaining their research and its implications to intermediaries. Joshua B. Powers reported in *The Chronicle of Higher Education* (September 22, 2006) that more than half of U.S. universities consistently lose money on technology transfer.

As the Australian policy and management consultant John Howard observes, researchers and research organizations will, except in very rare situations, earn more from being paid for their work in-

put in contracts and consultancies than from licenses and royalties flowing from IP or from income earned in spin-out companies.

I therefore suggest that – with the exception of biotechnology – public universities simply give away most IP as a contribution to the general good. This could be subject to universities including in their intellectual property licensing agreements a standard 'blockbuster' or 'jackpot' clause that provides that should their intellectual property contribute to 'blockbuster' revenues of, say, \$50 million over 10 years, there would be a sharing of revenue determined by a nominated commercial arbitrator.

*From Gavin Moodie,
Principal Policy Advisor,
Griffith University, Australia.
www.griffith.edu.au/vc/staff/moodie*

...but technology transfer is about more than revenue generation

As a Vice President of AUTM (the Association of University Technology Managers), I would stress that most university technology transfer offices do not have a primary goal of revenue generation. Professor Ogada (*IP in Universities: Putting Policies in Place – WIPO Magazine Issue no. 5/2006*) captures the goals of technology transfer well, including: promoting the dissemination of knowledge, and assuring stakeholders that risks, benefits and credit are distributed equitably.

AUTM does not tend to use revenue generation as an indicator of benefit. Rather, we use information about how the university distributes revenue received under licenses to benefit the university community; how products which are brought to market benefit everyone; and how innovative university-led licensing programs can push an industry or technology forward (among other measures).

A blanket “give it away” approach, on the other hand, usually benefits large companies, who are able to create and patent improvements to the “free” IP more rapidly than other organizations or individuals. For developing economies, or early-stage technology of all kinds, “free” can come with a heavy cost. Free still can achieve the best outcomes for everyone, but strategy is best determined on a case-by-case basis. Without resources to sustain a “free” commons, often only those with resources can benefit from what was released.

Over 500 new products became available last year as a result of licenses from U.S. and Canadian academic technology transfer efforts. More intangibly, universities benefit from the interaction with companies, to see how academic thinking and solutions can be applied to commercial problems. Ironically, universities also benefit from our academic community’s greater awareness of IP, as we live in a world where IP plays a greater role, and companies,

in their interactions with universities, demand greater accountability.

Ultimately, universities are increasingly being asked to demonstrate to their community the benefit they provide in the knowledge economy. U.S. and Canadian universities have over 28,000 active licenses at this time, which are all relationships that academic R&D centers have with organizations who have committed to using a given technology for the public benefit. Many are also members of PIPRA (Public Intellectual Property Resources for Agriculture), which encourages licensing with terms that allow agricultural technologies to be made more easily available for development and distribution of subsistence crops for humanitarian purposes in the developing world and specialty crops in the developed world.

*From Dana Bostrom,
Associate Director, Industry Alliances Office,
University of California, Berkeley*

Starting out

I read with interest the articles on university IP policies and technology transfer in the September-October edition of WIPO Magazine. At the *Universidad Nacional de Mar del Plata* in Argentina, we are currently taking the first steps along this road after creating an IP Office within the Technology Transfer secretariat.

Our Governing Council has recently approved a regulation which defines the scope, players, and procedures regarding the protection of any intellectual creation resulting from scientific or cultural research carried out within the University and/or with third parties. We have adopted an active IP awareness policy to reach those involved in this process, from the researchers, teaching staff and students, to members of the decision-making bodies. We are running conferences in the different academic units in order to explain the objectives, implications and advantages of IP protection, as well as of technology transfer between the university and external social/commercial *milieux*. We have also applied to join the WIPO University Initiative in order to appoint a coordinator and benefit from relevant IP reference materials.

So we are in the early phase of what will be a lengthy process, but one which, it is already clear, will bring economic, scientific and developmental benefits, not only to our University, but also to our broader society.

From Dr. Bernardo Marcos Diez, Secretariat for Technology Transfer (New Technologies Research Group), Faculty of Law, Universidad Nacional de Mar del Plata, Argentina.



The perfume debate

Is copyright the right route?



Courtesy of Lancôme

The article *Copyright in the Courts: Perfume as Artistic Expression?* (Issue 5/2006) raises the uncertain prospect, from a legal perspective, that any industrial product could be converted into a work eligible for protection under copyright legislation.

In this respect, we are left with the sense that the interpreters of the law are diverting the purpose of copyright. While the list of what may be considered *works* according to international copyright law is merely declaratory, that does not necessarily imply that everything is subject to protection. There are existing requirements which define the object of copyright.

In the specific case of perfumes, it should be stressed that what could potentially be protected is the chemical formula of which the fragrance consists, rather than the smell itself, since the consumer often cannot perceive slight differences in smell.

This is similar to the case of culinary recipes, whereby the recipe – not the taste – is protected.

Finally, from a business point of view, copyright protection is not the most profitable option for *parfumeurs*, since once the term of protection for the creator expires, the “work” enters the public domain, after which it is impossible to take action against unlawful use.

In Colombia it is possible to register smell marks in accordance with the requirements of Decision 344 of the Commission of the Cartagena Agreement (Article 8). This may be a more effective option, allowing firms such as Lancôme greater scope commercially and in the long term.

*From Catalina Castro Gaitán,
Palacio, Arenas & Vanegas,
Legal Corporate Consultants
Bogotá D.C., Colombia (www.pav-lcc.com)*

What the French courts found

In his account of the Dutch ruling on copyrighting perfume, Professor Koelman refers briefly to a French Supreme Court decision published just three days before the Dutch case. The French decision in fact shook up previous French case law in this area. The background is as follows.

The eligibility of perfumes for copyright protection was first introduced into French practice through a decision of the Paris first-degree court dated September 24, 1999.

The issue resurfaced five years later in a case involving L'Oréal and several other perfume companies which sued the cosmetics firm Bellure NV for copyright infringement, claiming that Bellure had reproduced their fragrances under different brands. The Paris first-degree court regarded perfumes as artistic works, comparing them to musical compositions. But the

claim was rejected because it lacked consistency. Extensive evidence of infringement was subsequently presented in the context of the appeal, including chemical analysis identifying 50 elements common to the two scents, olfactory tests on members of the public, an expert report by a professional “nose,” and gas chromatography.

In its ruling on January 25, 2006, the Court of Appeal clearly held that perfumes were eligible to copyright protection, considering that (i) they are identified through their smell “architecture” and (ii) the unusual and very specific combinations of essences show the creative work of their author.

But then came the latest decision of the French High Court on June 13, 2006, in which the judges retained that the creator of a perfume was *not* covered by copyright law. As

this decision was issued by the High Court, the question is settled in France as far as perfume creators are concerned. The question of counterfeiting, however, remains open as this was not included in the legal case submitted to the French High Court.

The extension of copyright grounds to perfumes would avoid the difficulties inherent in obtaining trademark registration for “smell-marks.” But it could also have negative effects, inasmuch as it increases the scope for infringement. Either way, any perfume considered insufficiently original to merit protection under copyright law would certainly risk seeing multiple copies emerge.

From Franck Soutaul and Jean-Philippe Bresson, European Trademark Attorneys, Inlex Conseil, Paris, France (www.inlex.com), and reporters for the IP Talk legal newsletter (www.ip-talk.eu).

Football scores high

Each World Cup brings with it new IP issues and ever higher returns from IP assets. Your article IP-related revenues and on the patented technologies used in the recent 2006 World Cup (Issue no. 4/2006) was of particular interest. Learning how much FIFA profited from clever exploitation of trademark and broadcasting rights was astonishing.

The value of IP rights increases by leaps and bounds as technology advances and IP owners become more aware of the existence of IP in every aspect of their product or service. The level of IP awareness by the average layperson in Malaysia is lower than in the U.S. and Europe. However, the Malaysian Ministry of Domestic Trade and Consumer Affairs has been active in holding events to provide more knowledge to the public about the importance of IP. Your FIFA article helps in raising public awareness, by aptly portraying how IP has an impact in many aspects of our lives, including sports.

The fact that there were 2,500 violations by counterfeiters in the 2006 World Cup even before the first match began is worrying. With the Asian Games 2006 and the Asian Cup 2007 around the corner, it seems that efforts to enforce IP rights should be at the forefront of the organizing strategy.

From P. Kandiah, Patent and Trademark Agent, KASS International Sdn Bhd, Kuala Lumpur, Malaysia

WIPO AWARD WINNERS

October-December

WIPO congratulates the following creators and inventors, who were presented with awards during the months of October, November and December.

WIPO Gold Medal for Invention

ARGENTINA

National Innovation Competition – INNOVAR 2006:

- In the product category: Rubén Schmit – for the Sphinx project
- In the agriculture category: Pablo Martín Bonadeo – for the Colossus Florida project
- In the applied sciences category: Fernando Sesma, Graciela Font De Valdez, Marti Medici, Verónica Molina – for their project to develop a fermented soy bean food product bioenriched with vitamins and calcium
- In the innovative concept category: Claudia Marina Lagier – for a biosensor for Chagas disease
- In the innovative activity category: IPEM N° 50 College – for its "Ingeniero Emilio Olmos"

CAMEROON

National Technologies Days Competition – 2006

- Bertin Tchinda - best inventor
- Béatrice Françoise Nijikam – best woman inventor
- Samuel Eugène Epesse Misse – best inventor

VIETNAM

Vietnam Nationwide Creativity Competition for Youth, Children:

- Duong Viet Cuong – for his Digital House
- Le Trung Minh Quan – for his automated wall painting robot



The first WIPO awards granted in the areas of traditional knowledge and folklore were bestowed upon Omayra Casamá, Beleida Espino R., Aquilina Gallegos and Sonia Henríquez in September. They received Creativity Awards in recognition of their contributions to the protection and promotion of the creativity and cultural heritage of Panama's indigenous peoples.

WIPO Creativity Award

RUSSIAN FEDERATION

- Mr. Ivan A. Bliznets – for his contribution to the development of IP legislation, education and training

REPUBLIC OF UZBEKISTAN

- Mr. R. Abdullaev – for his achievements as an author

WIPO Trophy for Innovative Enterprises

MOROCCO

- *Fondation Suisse Maroc pour le Développement Durable (FSMD)* – for its contributions to technological innovation and advancement and its use of the IP system in the development and commercialization of products and services

Calendar of Meetings

NOVEMBER 13 TO 17 ■ GENEVA

■ *Standing Committee on the Law of Trademarks, Industrial Designs and Geographical Indications (SCT) (Sixteenth session)*

The Committee will work on new issues as identified by the SCT at its Fifteenth session, in particular new types of marks, trademark opposition procedures, the harmonization of formalities concerning the procedures for design registration and the relationship between trademarks and some aspects of copyright law.

Invitations: As members, the States members of WIPO and/or the Paris Union; as observers, other States and certain organizations.

NOVEMBER 15 ■ GENEVA

■ *Seminar on the Hague System of International Registration of Industrial Designs*

This Seminar, in English and French, is aimed at increasing awareness and practical knowledge of the Hague system for the international registration of industrial designs among industry and private practitioners who use, or will use, the system.

Invitations: Registration is open to all interested parties subject to the payment of a registration fee. The competent authorities of the States members of the Hague Union will be exempt from the payment of the fee.

NOVEMBER 16 AND 17 ■ GENEVA

■ *Seminar on the Madrid System of International Registration of Marks*

This Seminar, in English, aims at increasing awareness and practical knowledge of the Madrid system among trademark agents who use, or will use, the system whether in industry or in private practice. These Seminars are held regularly every year, both in English and French.

Invitations: Registration is open to interested parties, subject to the payment of a registration fee. The competent authorities of the States members of the Madrid Union will be exempt from the payment of the fee.

NOVEMBER 27 TO DECEMBER 1 ■ GENEVA

■ *IPC Revision Working Group of the IPC Union (Sixteenth session)*

The Working Group will continue preparation of revision amendments to the eighth edition of the IPC and implementation of results of IPC reform and will complete preparation of IPC training examples.

Invitations: As members, the States members of the IPC Union and member organizations of the Working Group; as observers, the States members of the Paris Union and certain organizations.

NOVEMBER 30 TO DECEMBER 8 ■ GENEVA

■ *Intergovernmental Committee on Intellectual Property and Genetic Resources, Traditional Knowledge and Folklore (Tenth session)*

The Committee will continue its work based on the renewed mandate established by the General Assembly, will consider draft texts of policy objectives and principles for the protection of traditional knowledge and traditional cultural expressions/folklore, and other ongoing work.

Invitations: As members, the States members of WIPO and/or the Paris Union, and the European Community; as observers, certain organizations.

NEW PRODUCTS



Patent Cooperation Treaty (PCT) and Regulations under the PCT 2006: Russian no. 274R, Spanish no. 274S
20 Swiss francs (plus shipping and handling)



La Propiedad Intelectual en las Pequeñas y Medianas Empresas: el Caso Chileno
Spanish no. 795S
25 Swiss francs (plus shipping and handling)

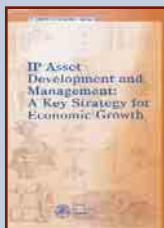

IP Asset Development and Management: A Key Strategy for Economic Growth
English no. 896E (updated reprint)
15 Swiss francs (plus shipping and handling)



Annual Report 2005
English no. 441E, French no. 441F, Spanish no. 441S
Free of charge



Summaries of Conventions, Treaties and Agreements Administered by WIPO, 2006
English no. 442E
Free of charge



Protecting Your Inventions Abroad: Frequently Asked Questions About the Patent Cooperation Treaty (PCT)
Arabic no. 433A, Chinese no. 433C, Russian no. 433R
Free of charge



Master of Laws in Intellectual Property - Post-Graduate Specialization Course on Intellectual Property - Collection of Research Papers, 2005
English no. 797E
Free of charge



NEW PRODUCTS



A Stitch in Time - Smart Use of Intellectual Property by Textile Companies

English no. 794E
Free of Charge



The International Patent System in 2005 - PCT Yearly Review

English no. 901E, French no. 901F, Spanish no. 901S
Free of charge



Patentscope - Access to the World of Technology

Japanese no. L434(J), Korean no. L434(K)
Free of Charge

Purchase publications online: www.wipo.int/ebookshop

Download free information products: www.wipo.int/publications/

The above publications may also be obtained from WIPO's Design, Marketing, and Distribution Section: 34, chemin des Colombettes, P.O. Box 18, CH-1211 Geneva 20, Switzerland | Fax: +41 22 740 18 12 | e-mail: publications.mail@wipo.int

Orders should indicate: **(a)** the number or letter code of the publication desired, the language, the number of copies, **(b)** the full address for mailing, **(c)** the mail mode (surface or air).

For more information contact
WIPO at:

Address:

34, chemin des Colombettes
P.O. Box 18
CH-1211 Geneva 20
Switzerland

Telephone:

+41 22 338 91 11

Fax:

+41 22 733 54 28

e-mail:

wipo.mail@wipo.int

or its New York Coordination
Office at:

Address:

2, United Nations Plaza
Suite 2525
New York, N.Y. 10017
United States of America

Telephone:

+1 212 963 6813

Fax:

+1 212 963 4801

e-mail:

wipo@un.org

Visit the WIPO website at:

www.wipo.int

**and order from the WIPO Electronic
Bookshop at**

www.wipo.int/ebookshop

The WIPO Magazine is published bimonthly by the Communications and Public Outreach Division, World Intellectual Property Organization (WIPO). The views expressed in individual articles are not necessarily those of WIPO.

The WIPO Magazine is distributed free of charge.

If you are interested in receiving copies, contact:

Design, Marketing, and Distribution Section
WIPO
34, chemin des Colombettes
P.O. Box 18
CH-1211 Geneva 20
Switzerland
Fax: +41 22 740 18 12
e-mail: publications.mail@wipo.int

For comments or questions, contact:

The Editor, WIPO Magazine
WipoMagazine@wipo.int

Copyright ©2006 World Intellectual Property Organization

All rights reserved. Articles contained herein may be reproduced for educational purposes. No part may, however, be reproduced for commercial purposes without the express written consent of the Communications and Public Outreach Division, World Intellectual Property Organization, P.O. Box 18, CH-1211 Geneva 20, Switzerland.